

## Unit 8(Exponents & Powers)

### Multiple Choice Questions

Question. 1 In  $2^n$ , n is known as

- (a) base (b) constant
- (c) exponent (d) variable

Solution.

(c) We know that an is called the nth power of a; and is also read as a raised to the power n. The rational number a is called the base and n is called the exponent (power or index). In the same way in  $2^n$ , n is known as exponent.

Question. 2 For a fixed base, if the exponent decreases by 1, the number becomes

- (a) one-tenth of the previous number
- (b) ten times of the previous number
- (c) hundredth of the previous number
- (d) hundred times of the previous number

Solution.

(a) For a fixed base, if the exponent decreases by 1, the number becomes one-tenth of the previous number.

e.g. For  $10^5$ , exponent decreases by 1.

i.e.  $10^{5-1} = 10^4$

$\therefore \frac{10^5}{10^5} = \frac{1}{10}$

Note: Option (a) is possible only, if we taken base as 10.

Question. 3

$3^{-2}$  can be written as

- (a)  $3^2$
- (b)  $\frac{1}{3^2}$
- (c)  $\frac{1}{3^{-2}}$
- (d)  $-\frac{2}{3}$

Solution.

(b) Using law of exponents,  $a^{-n} = \frac{1}{a^n}$  [ $\because a$  is non-zero integer]

So, we can write  $3^{-2}$  as  $\frac{1}{3^2}$ .

Question. 4 The value of  $1/4^{-2}$  is

Solution.

(a) Using law of exponents,  $a^{-m} = \frac{1}{a^m}$  [ $\because a$  is non-zero integer]

$$\therefore \frac{1}{4^{-2}} = \frac{1}{\frac{1}{4^2}} = \frac{1}{1} \times 16 = 16$$

Question. 5 The value of  $3^5 \div 3^{-6}$  is

(a)  $3^5$  (b)  $3^{-6}$  (c)  $3^{11}$  (d)  $3^{-11}$

Solution.

(c) Using law of exponents,  $a^m \div a^n = a^{m-n}$  [ $\because a$  is non-zero integer]

$$\therefore 3^5 \div 3^{-6} = 3^{5-(-6)} = 3^{5+6} = 3^{11}$$

Question. 6

The value of  $\left(\frac{2}{5}\right)^{-2}$  is

(a)  $\frac{4}{5}$  (b)  $\frac{4}{25}$  (c)  $\frac{25}{4}$  (d)  $\frac{5}{2}$

Solution.

(c) Using law of exponents,  $a^{-m} = \frac{1}{a^m}$  [ $\because a$  is non-zero integer]

$$\therefore \left(\frac{2}{5}\right)^{-2} = \frac{1}{\left(\frac{2}{5}\right)^2} = \frac{1}{\frac{4}{25}} = \frac{25}{4}$$

Question. 7

7 The reciprocal of  $\left(\frac{2}{5}\right)^{-1}$  is

(a)  $\frac{2}{5}$  (b)  $\frac{5}{2}$  (c)  $-\frac{5}{2}$  (d)  $-\frac{2}{5}$

Solution.

(b) Using law of exponents,  $a^{-m} = \frac{1}{a^m}$  [ $\because a$  is non-zero integer]

$$\therefore \left(\frac{2}{5}\right)^{-1} = \frac{1}{\left(\frac{2}{5}\right)^1} = \frac{5}{2}$$

Question. 8 The multiplicative inverse of  $10^{-100}$  is

(a) 10 (b) 100 (c)  $10^{100}$  (d)  $10^{-100}$

Solution.

For multiplicative inverse, let  $a$  be the multiplicative inverse of  $10^{-100}$ .

So,  $a \times b = 1$

$\therefore a \times 10^{-100} = 1$

$$\Rightarrow a = \frac{1}{10^{-100}} = \frac{1}{\frac{1}{10^{100}}} = 10^{100} \quad \left[ \because a^{-m} = \frac{1}{a^m} \right]$$

Question.9 The value of  $(-2)^{2 \times 3-1}$  is

(a) 32 (b) 64 (c) -32 (d) -64

Solution.

(c) Given,  $(-2)^{2 \times 3 - 1} = (-2)^{6-1} = (-2)^5$   
 $= (-2) \times (-2) \times (-2) \times (-2) \times (-2) = -32$   
[for  $(-a)^m$ , if  $m$  is odd, then  $(-a)^m$  is negative]

Question.10

The value of  $\left(-\frac{2}{3}\right)^4$  is equal to

- (a)  $\frac{16}{81}$       (b)  $\frac{81}{16}$       (c)  $\frac{-16}{81}$       (d)  $\frac{81}{-16}$

Solution.

(a) Given,  $\left(-\frac{2}{3}\right)^4 = \left(-\frac{2}{3}\right) \times \left(-\frac{2}{3}\right) \times \left(-\frac{2}{3}\right) \times \left(-\frac{2}{3}\right) = \frac{16}{81}$   
[for  $(-a)^m$ , if  $m$  is even, then  $(-a)^m$  is positive]

Question. 11

The multiplicative inverse of  $\left(-\frac{5}{9}\right)^{-99}$  is

- (a)  $\left(-\frac{5}{9}\right)^{99}$       (b)  $\left(\frac{5}{9}\right)^{99}$       (c)  $\left(\frac{9}{-5}\right)^{99}$       (d)  $\left(\frac{9}{5}\right)^{99}$

Solution.

(a) For multiplicative inverse, a is called multiplicative inverse of b, if  $a \times b = 1$ .

Put  $b = \left(-\frac{5}{9}\right)^{-99} \Rightarrow a \times \left(-\frac{5}{9}\right)^{-99} = 1$   
 $\Rightarrow a = \frac{1}{\left(-\frac{5}{9}\right)^{-99}} \Rightarrow a = \left(-\frac{5}{9}\right)^{99}$       [∵  $a^{-m} = \frac{1}{a^m}$ ]

Question. 12 If x be any non-zero integer and w, n be negative integers, then  $x^m \times x^n$  is equal to

- (a)  $x^m$       (b)  $x^{(m+n)}$       (c)  $x^n$       (d)  $x^{(m-n)}$

Solution.

(b) Using law of exponents,  
 $a^m \times a^n = (a)^{m+n}$       [∵ a is non-zero integer]  
Similarly,  $x^m \times x^n = (x)^{m+n}$

Question. 13 If y be any non-zero integer, then  $y^0$  is equal to

- (a) 1      (b) 0      (c) -1      (d) not defined

Solution.

(a) Using law of exponents,  
 $a^0 = 1$       [∵ a is non-zero integer]  
Similarly,  $y^0 = 1$

Question.14 If x be any non-zero integer, then  $x^{-1}$  is equal to

- (a) x      (b) 1/x      (c) -x      (d) -1/x

Solution.

(b) Using law of exponents,  $a^{-m} = \frac{1}{a^m}$       [∵ a is non-zero integer]  
Similarly,  $x^{-1} = \frac{1}{x}$

Question. 15

If  $x$  be any integer different from zero and  $m$  be any positive integer, then  $x^{-m}$  is equal to

- (a)  $x^m$                       (b)  $-x^m$                       (c)  $\frac{1}{x^m}$                       (d)  $\frac{-1}{x^m}$

Solution.

(c) Using law of exponents,  $a^{-m} = \frac{1}{a^m}$  [ $\because a$  is non-zero integer]

Similarly,  $x^{-m} = \frac{1}{x^m}$

Question. 16

If  $x$  be any integer different from zero and  $m, n$  be any integers, then  $(x^m)^n$  is equal to

- (a)  $x^{m+n}$                       (b)  $x^{mn}$                       (c)  $\frac{m}{x^n}$                       (d)  $x^{m-n}$

Solution.

(b) Using law of exponents,  $(a^m)^n = (a)^{m \times n}$  [ $\because a$  is non-zero integer]

Similarly,  $(x^m)^n = (x)^{m \times n} = (x)^{mn}$

Question. 17

Which of the following is equal to  $\left(-\frac{3}{4}\right)^{-5}$ ?

- (a)  $\left(\frac{3}{4}\right)^{-3}$                       (b)  $-\left(\frac{3}{4}\right)^{-3}$                       (c)  $\left(\frac{4}{3}\right)^3$                       (d)  $\left(-\frac{4}{3}\right)^3$

Solution.

(d) Given,  $\left(-\frac{3}{4}\right)^{-3}$

Using law of exponents,  $a^{-m} = \frac{1}{a^m}$  [ $\because a$  is non-zero integer]

$\therefore \left(-\frac{3}{4}\right)^{-3} = \frac{1}{\left(-\frac{3}{4}\right)^3} = \left(-\frac{4}{3}\right)^3$

Question. 18

$\left(-\frac{5}{7}\right)^{-5}$  is equal to

- (a)  $\left(\frac{5}{7}\right)^{-5}$                       (b)  $\left(\frac{5}{7}\right)^5$                       (c)  $\left(\frac{7}{5}\right)^5$                       (d)  $\left(-\frac{7}{5}\right)^5$

Solution.

(d) Using law of exponents,  $a^{-m} = \frac{1}{a^m}$  [ $\because a$  is non-zero integer]

$\therefore \left(-\frac{5}{7}\right)^{-5} = \frac{1}{\left(-\frac{5}{7}\right)^5} = \left(-\frac{7}{5}\right)^5$

Question. 19

$\left(\frac{-7}{5}\right)^{-1}$  is equal to

- (a)  $\frac{5}{7}$                       (b)  $-\frac{5}{7}$                       (c)  $\frac{7}{5}$                       (d)  $\frac{-7}{5}$

Solution.

(b) Using law of exponents,  $a^{-m} = \frac{1}{a^m}$  [ $\because a$  is non-zero integer]

$$\therefore \left(\frac{-7}{5}\right)^{-1} = \frac{1}{\left(\frac{-7}{5}\right)} = \left(\frac{-5}{7}\right)$$

Question. 20

$(-9)^3 + (-9)^8$  is equal to

- (a)  $(9)^3$  (b)  $(9)^{-5}$  (c)  $(-9)^5$  (d)  $(-9)^{-5}$

Solution.

(d) Given,  $(-9)^3 + (-9)^8$

Using law of exponents,  $a^m + a^n = (a)^{m-n}$  [ $\because a$  is non-zero integer]

$$\therefore (-9)^3 + (-9)^8 = (-9)^{3-8} = (-9)^{-5}$$

Question. 21

Cube of  $-\frac{1}{2}$  is

- (a)  $\frac{1}{8}$  (b)  $\frac{1}{16}$   
(c)  $-\frac{1}{8}$  (d)  $-\frac{1}{16}$

Solution.

(c) Using law of exponents,  $a^m + a^n = (a)^{m-n}$  [ $\because a$  is non-zero integer]

$$\text{Similarly, } x^7 + x^{12} = (x)^{7-12} = (x)^{-5}$$

Question. 22

For a non-zero integer  $x$ ,  $(x^4)^{-3}$  is equal to

- (a)  $x^{12}$  (b)  $x^{-12}$  (c)  $x^{64}$  (d)  $x^{-64}$

Solution.

(b) Using law of exponents,  $(a^m)^n = (a)^{m \times n} = (a)^{mn}$  [ $\because a$  is non-zero integer]

$$\text{Similarly, } (x^4)^{-3} = (x)^{4 \times (-3)} = (x)^{-12}$$

Question. 23

The value of  $(7^{-1} - 8^{-1})^{-1} - (3^{-1} - 4^{-1})^{-1}$  is

- (a) 44 (b) 56 (c) 68 (d) 12

Solution.

(a) Using law of exponents,  $a^{-m} = \frac{1}{a^m}$  [ $\because a$  is non-zero integer]

$$\begin{aligned} \therefore (7^{-1} - 8^{-1})^{-1} - (3^{-1} - 4^{-1})^{-1} \\ &= \left(\frac{1}{7} - \frac{1}{8}\right)^{-1} - \left(\frac{1}{3} - \frac{1}{4}\right)^{-1} \\ &= \left(\frac{1}{56}\right)^{-1} - \left(\frac{1}{12}\right)^{-1} = 56 - 12 = 44 \end{aligned}$$

Question.24 The standard form for 0.000064 is

- (a)  $64 \times 10^4$  (b)  $64 \times 10^{-4}$  (c)  $6.4 \times 10^5$  (d)  $6.4 \times 10^{-5}$

Solution.

(d) Given,  $0.000064 = 0.64 \times 10^{-4} = 6.4 \times 10^{-5}$

Hence, standard form of 0.000064 is  $6.4 \times 10^{-5}$ .

Question. 25 The standard form for 234000000 is

- (a)  $2.34 \times 10^8$  (b)  $0.234 \times 10^9$   
(c)  $2.34 \times 10^{-8}$  (d)  $0.234 \times 10^{-9}$

Solution.

(a) Given,  $234000000 = 234 \times 10^6 = 2.34 \times 10^{+6} = 2.34 \times 10^8$   
Hence, standard form of 234000000 is  $2.34 \times 10^8$ .

Question.26 The usual form for  $2.03 \times 10^{-5}$  is

- (a) 0.203 (b) 0.00203 (c) 203000 (d) 0.0000203

Solution.

(d) Given,  $2.03 \times 10^{-5} = 0.0000203$   
[∵ placing decimal five digit towards left of original position]

Question. 27

$\left(\frac{1}{10}\right)^0$  is equal to

- (a) 0 (b)  $\frac{1}{10}$  (c) 1 (d) 10

Solution.

(c) Using law of exponents,  $a^0 = 1$  [∵ a is non-zero integer]  
∴  $\left(\frac{1}{10}\right)^0 = 1$

Question. 28

$\left(\frac{3}{4}\right)^5 + \left(\frac{5}{3}\right)^5$  is equal to

- (a)  $\left(\frac{3}{4} + \frac{5}{3}\right)^5$  (b)  $\left(\frac{3}{4} + \frac{5}{3}\right)^1$  (c)  $\left(\frac{3}{4} + \frac{5}{3}\right)^0$  (d)  $\left(\frac{3}{4} + \frac{5}{3}\right)^{10}$

Solution.

(a) Using law of exponents,  $a^m + b^m = (a + b)^m$  [∵ a and b are non-zero integers]  
∴  $\left(\frac{3}{4}\right)^5 + \left(\frac{5}{3}\right)^5 = \left(\frac{3}{4} + \frac{5}{3}\right)^5$

Question. 29

For any two non-zero rational numbers x and y,  $x^4 + y^4$  is equal to

- (a)  $(x + y)^0$  (b)  $(x + y)^1$   
(c)  $(x + y)^4$  (d)  $(x + y)^6$

Solution.

(c) Using law of exponents,  $\frac{a^m}{b^m} = \left(\frac{a}{b}\right)^m = (a + b)^m$  [∵ a and b are non-zero integers]  
Similarly,  $x^4 + y^4 = \left(\frac{x}{y}\right)^4 = (x + y)^4$

Question. 30

For a non-zero rational number p,  $p^{13} + p^8$  is equal to

- (a)  $p^5$  (b)  $p^{21}$   
(c)  $p^{-5}$  (d)  $p^{-19}$

Solution.

(a) Using law of exponents,  $a^m + a^n = (a)^{m+n}$  [∵ a is non-zero integer]  
Similarly,  $p^{13} + p^8 = (p)^{13+8} = (p)^{21}$

Question. 31

For a non-zero rational number z,  $(z^{-2})^3$  is equal to

- (a)  $z^6$  (b)  $z^{-6}$   
(c)  $z^1$  (d)  $z^4$

Solution.

(b) Using law of exponents,  $(a^m)^n = (a)^{mn}$

[∵ a is non-zero integer]

Similarly,  $(z^{-2})^3 = (z)^{(-2) \times 3} = (z)^{-6}$

Question. 32

Cube of  $-\frac{1}{2}$  is

(a)  $\frac{1}{8}$

(b)  $\frac{1}{16}$

(c)  $-\frac{1}{8}$

(d)  $-\frac{1}{16}$

Solution.

(c) Cube of a is  $(a)^3 = a \times a \times a$

Similarly,  $\left(-\frac{1}{2}\right)^3 = \left(-\frac{1}{2}\right) \times \left(-\frac{1}{2}\right) \times \left(-\frac{1}{2}\right) = \left(-\frac{1}{8}\right)$

[for  $(-a)^m$ , if m is odd, then  $(-a)^m$  is negative]

Question. 33

Which of the following is not the reciprocal of  $\left(\frac{2}{3}\right)^4$ ?

(a)  $\left(\frac{3}{2}\right)^4$

(b)  $\left(\frac{3}{2}\right)^{-4}$

(c)  $\left(\frac{2}{3}\right)^{-4}$

(d)  $\frac{3^4}{2^4}$

Solution.

(b) Reciprocal of a is  $\frac{1}{a}$

Similarly,  $\left(\frac{2}{3}\right)^4 = \left(\frac{3}{2}\right)^4 = \frac{3^4}{2^4} = \left(\frac{2}{3}\right)^{-4}$

Hence, option (b) is not the reciprocal of  $\left(\frac{2}{3}\right)^4$

Fill in the Blanks

In questions 34 to 65, fill in the blanks to make the statements true.

Question. 34 The multiplicative inverse of  $10^{10}$  is \_\_\_\_\_

Solution.

For multiplicative inverse, a is called the multiplicative inverse of b, if  $a \times b = 1$

Put  $b = 10^{10}$

Then,  $a \times 10^{10} = 1 \Rightarrow a = \frac{1}{10^{10}}$

$\left[\because \frac{1}{a^m} = a^{-m}\right]$

$\therefore a = 10^{-10}$

Hence, the multiplicative inverse of  $10^{10}$  is  $10^{-10}$

Question.35  $a^3 \times a^{-10} =$  \_\_\_\_\_

Solution.

Given,  $a^3 \times a^{-10}$

Using law of exponents,  $a^m \times a^n = (a)^{m+n}$

[∵ a is non-zero integer]

Similarly,  $a^3 \times a^{-10} = (a)^{3-10} = (a)^{-7}$

Hence,  $a^3 \times a^{-10} = a^{-7}$

Question.36  $5^0 =$  \_\_\_\_\_

Solution.

Using law of exponents,  $a^0 = 1$

[ $\because a$  is non-zero integer]

$$\therefore 5^0 = 1$$

Hence,  $5^0 = 1$

Question.37  $5^5 \times 5^{-5} =$  \_\_\_\_\_

Solution.

Using law of exponents,  $a^m \times a^n = (a)^{m+n}$

[ $\because a$  is non-zero integer]

$$\therefore 5^5 \times 5^{-5} = (5)^{5-5} = (5)^0 = 1$$

[ $\because a^0 = 1$ ]

Hence,  $5^5 \times 5^{-5} = 1$

Question.38

The value of  $\left(\frac{1}{2^3}\right)^2$  is equal to \_\_\_\_\_

Solution.

Using law of exponents,  $(a^m)^n = (a)^{mn}$

[ $\because a$  is non-zero integer]

$$\therefore \left(\frac{1}{2^3}\right)^2 = \left(\frac{1^2}{2^3}\right)^2 = \left(\frac{1}{2}\right)^{3 \times 2} = \left(\frac{1}{2}\right)^6 = \frac{1}{2^6}$$

[ $\because (1)^m = 1$ ]

$$\text{Hence, } \left(\frac{1}{2^3}\right)^2 = \frac{1}{2^6}$$

Question. 39 The expression for  $8^{-2}$  as a power with the base 2 is \_\_\_\_\_

Solution.

Given,  $8^{-2}$ , where we can write  $8 = 2 \times 2 \times 2$

$$\therefore (2 \times 2 \times 2)^{-2} = (2)^{3 \times (-2)} = (2)^{-6}$$

Hence,  $8^{-2} = (2)^{-6}$

Question. 40 Very small numbers can be expressed in standard form by using \_\_\_\_\_ exponents

Solution.

Very small numbers can be expressed in standard form by using negative exponents, i.e.

$$0.000023 = 2.3 \times 10^{-3}$$

Question. 41 Very large numbers can be expressed in standard form by using \_\_\_\_\_ exponents.

Solution.

Very large numbers can be expressed in standard form by using positive exponents,

$$\text{i.e. } 23000 = 23 \times 10^3 = 2.3 \times 10^3 \times 10^1 = 2.3 \times 10^4$$

Question. 42 By multiplying  $(10)^5$  by  $(10)^{-10}$ , we get

Solution.

Using law of exponents,  $(a)^m \times (a)^n = (a)^{m+n}$

[ $\because a$  is non-zero integer]

$$\text{Similarly, } (10)^5 \times (10)^{-10} = (10)^{5-10} = (10)^{-5}$$

$$\text{Hence, } (10)^5 \times (10)^{-10} = (10)^{-5}$$

Question.43

$$\left[ \left(\frac{2}{13}\right)^{-6} + \left(\frac{2}{13}\right)^3 \right] \times \left(\frac{2}{13}\right)^{-4} = \text{_____}$$

Solution.



Using laws of exponents,  $a^m + a^n = (a)^{m-n}$  and  $a^m \times a^n = (a)^{m+n}$  [ $\because a$  is non-zero integer]

$$\begin{aligned} \therefore \left[ \left( \frac{2}{13} \right)^6 + \left( \frac{2}{13} \right)^3 \right]^7 \times \left( \frac{2}{13} \right)^{-9} &= \left[ \left( \frac{2}{13} \right)^{-6-3} \right]^7 \times \left( \frac{2}{13} \right)^{-9} \\ &= \left( \frac{2}{13} \right)^{-27} \times \left( \frac{2}{13} \right)^{-9} \\ &= \left( \frac{2}{13} \right)^{-27-9} = \left( \frac{2}{13} \right)^{-36} \end{aligned}$$

Hence,  $\left[ \left( \frac{2}{13} \right)^6 + \left( \frac{2}{13} \right)^3 \right]^7 \times \left( \frac{2}{13} \right)^{-9} = \left( \frac{2}{13} \right)^{-36}$

Question.44

$$[4^{-1} + 3^{-1} + 6^{-2}]^{-1} = \underline{\hspace{2cm}}$$

Solution.

Using law of exponents,  $a^{-m} = \frac{1}{a^m}$  [ $\because a$  is non-zero integer]

$$\begin{aligned} \therefore [4^{-1} + 3^{-1} + 6^{-2}]^{-1} &= \left( \frac{1}{4} + \frac{1}{3} + \frac{1}{36} \right)^{-1} = \left( \frac{9 + 12 + 1}{36} \right)^{-1} \quad [\because \text{LCM of } 4, 3 \text{ and } 36 = 36] \\ &= \left( \frac{22}{36} \right)^{-1} = \frac{36}{22} = \frac{18}{11} \end{aligned}$$

Hence,  $[4^{-1} + 3^{-1} + 6^{-2}]^{-1} = \frac{18}{11}$

Question.45

$$[2^{-1} + 3^{-1} + 4^{-1}]^0 = \underline{\hspace{2cm}}$$

Solution.

Using law of exponents,  $a^0 = 1$  [ $\because a$  is non-zero integer]

$$\therefore [2^{-1} + 3^{-1} + 4^{-1}]^0 = 1$$

Hence,  $[2^{-1} + 3^{-1} + 4^{-1}]^0 = 1$

Question.46

The standard form of  $\left( \frac{1}{100000000} \right)$  is \_\_\_\_\_.

Solution.

$$\text{For standard form, } \frac{1}{100000000} = \frac{1}{1 \times 10^8} = \frac{1}{10^8} = 1 \times 10^{-8} = 1.0 \times 10^{-8}$$

Hence, standard form of  $\frac{1}{100000000}$  is  $1.0 \times 10^{-8}$ .

Question.47

The standard form of 12340000 is \_\_\_\_\_.

Solution.

$$\begin{aligned} \text{For standard form, } 12340000 &= 1234 \times 10^4 \\ &= 1234 \times 10^4 \times 10^3 = 1234 \times 10^7 \end{aligned}$$

Hence, the standard form of 12340000 is  $1.234 \times 10^7$ .

Question.48

The usual form of  $3.41 \times 10^6$  is \_\_\_\_\_.

Solution.

$$\text{For usual form, } 3.41 \times 10^6 = 3.41 \times 10 \times 10 \times 10 \times 10 \times 10 \times 10 = 3410000$$

Hence, the usual form of  $3.41 \times 10^6$  is **3410000**.

Question.49

The usual form of  $2.39461 \times 10^8$  is \_\_\_\_\_.

Solution.

For usual form,  $2.39461 \times 10^8 = 2.39461 \times 10 \times 10 \times 10 \times 10 \times 10 \times 10 \times 10 \times 10 = 2394610$

Hence, the usual form of  $2.39461 \times 10^8$  is **2394610**.

Question.50

If  $36 = 6 \times 6 = 6^2$ , then  $\frac{1}{36}$  expressed as a power with the base 6 is \_\_\_\_\_.

Solution.

Given,  $36 = 6 \times 6 = 6^2$

So,  $\frac{1}{36} = \frac{1}{6 \times 6} = \frac{1}{(6)^2} = (6)^{-2}$  [ $\because a^{-m} = \frac{1}{a^m}$ ]

Question.51

By multiplying  $(\frac{5}{3})^4$  by \_\_\_\_\_, we get  $5^4$ .

Solution.

Let x be multiplied with  $(\frac{5}{3})^4$  to get  $5^4$ .

So,  $(\frac{5}{3})^4 \times x = 5^4$

$\therefore x = \frac{5^4}{(\frac{5}{3})^4} = 5^0 \times 3^4 \times 5^{-4} = (5)^{4-4} \times 3^4$  [ $\because a^{-m} = \frac{1}{a^m}, a^m \times a^n = (a)^{m+n}$ ]  
 $= 5^0 \times 3^4 = 1 \times 81 = 81$  [ $\because a^0 = 1$ ]

Question.52

$3^5 + 3^{-6}$  can be simplified as \_\_\_\_\_.

Solution.

Given,  $3^5 + 3^{-6} = (3)^{5-(-6)} = (3)^{5+6} = (3)^{11}$  [ $\because a^m + a^n = (a)^{m+n}$ ]

Hence,  $3^5 + 3^{-6}$  can be simplified as  **$(3)^{11}$** .

Question.53 The value of  $3 \times 10^{-7}$  is equal to\_\_\_\_\_

Solution

Given,  $3 \times 10^{-7} = 3.0 \times 10^{-7}$

Now, placing decimal seven place towards left of original position, we get 0.0000003. Hence, the value of  $3 \times 10^{-7}$  is equal to 0.0000003.

Question.54 To add the numbers given in standard form, we first convert them into number with\_\_\_\_\_exponents.

Solution.

To add the numbers given in standard form, we first convert them into numbers with equal exponents.

e.g.  $2.46 \times 10^6 + 24.6 \times 10^5 = 2.46 \times 10^5 + 2.46 \times 10^6 = 4.92 \times 10^6$

Question.55 The standard form for 32500000000 is\_\_\_\_\_.

Solution.

For standard form,  $32500000000 = 3250 \times 10^2 \times 10^2 \times 10^3$   
 $= 3250 \times 10^7 = 3.250 \times 10^{10}$  or  $3.25 \times 10^{10}$

Hence, the standard form for 32500000000 is  $3.25 \times 10^{10}$ .

Question. 56 The standard form for 0.000000008 is\_\_\_\_\_.

Solution.

For standard form,  $0.000000008 = 0.8 \times 10^{-8} = 8 \times 10^{-9} = 8.0 \times 10^{-9}$

Hence, the standard form for 0.000000008 is  $8.0 \times 10^{-9}$

Question.57 The usual form for  $2.3 \times 10^{-10}$  is\_\_\_\_\_.

Solution. For usual form,  $2.3 \times 10^{-10} = 0.23 \times 10^{-11}$

$= 0.00000000023$

Hence, the usual form for  $2.3 \times 10^{-10}$  is 0.00000000023.

Question. 58 On dividing  $8^5$  by\_\_\_\_\_ we get 8.

Solution.

Let  $8^5$  be divided by  $x$  to get 8.

$$\text{So, } 8^5 \div x = 8$$

$$\Rightarrow 8^5 \times \frac{1}{x} = 8$$

$$\Rightarrow \frac{8^5}{8} = x$$

$$\therefore x = \frac{8^5}{8^1} = 8^{5-1} = 8^4 \quad [\because a^m \div a^n = (a)^{m-n}]$$

Question. 59

On multiplying \_\_\_\_\_ by  $2^{-5}$ , we get  $2^5$ .

Solution.

Let  $x$  be multiplied by  $2^{-5}$  to get  $2^5$ .

$$\text{So, } x \times 2^{-5} = 2^5$$

$$\Rightarrow x \times \frac{1}{2^5} = 2^5$$

$$\therefore x = 2^5 \times 2^5 = (2)^{5+5} = 2^{10} \quad [\because a^m \times a^n = (a)^{m+n}]$$

Question. 60

The value of  $[3^{-1} \times 4^{-1}]^2$  is \_\_\_\_\_.

Solution.

Using law of exponents,  $a^{-m} = \frac{1}{a^m}$  [ $\because a$  is non-zero integer]

$$\therefore [3^{-1} \times 4^{-1}]^2 = \left(\frac{1}{3} \times \frac{1}{4}\right)^2 = \left(\frac{1}{12}\right)^2$$
$$= 12^{-2} = \frac{1}{144}$$

$$\text{Hence, } [3^{-1} \times 4^{-1}]^2 = \frac{1}{144}$$

Question.61

The value of  $[2^{-1} \times 3^{-1}]^{-1}$  is \_\_\_\_\_.

Solution.

Using law of exponents,  $a^{-m} = \frac{1}{a^m}$  [ $\because a$  is non-zero integer]

$$\therefore [2^{-1} \times 3^{-1}]^{-1} = \left(\frac{1}{2} \times \frac{1}{3}\right)^{-1} = \left(\frac{1}{6}\right)^{-1} = 6$$

$$\text{Hence, } [2^{-1} \times 3^{-1}]^{-1} = 6$$

Question.62

By solving  $(6^0 - 7^0) \times (6^0 + 7^0)$ , we get \_\_\_\_\_.

Solution.

Using law of exponents,  $a^0 = 1$

[ $\because a$  is non-zero integer]

$$\therefore (6^0 - 7^0) \times (6^0 + 7^0) = (1 - 1) \times (1 + 1) = 0 \times 2 = 0$$

$$\text{Hence, } (6^0 - 7^0) \times (6^0 + 7^0) = 0$$

Question.63

The expression for  $3^5$  with a negative exponent is \_\_\_\_\_.

Solution.

Using law of exponents,  $a^{-m} = \frac{1}{a^m}$

[ $\because a$  is non-zero integer]

$$\therefore 3^5 = \frac{1}{3^{-5}}$$

Hence, the expression for  $3^5$  with a negative exponent is  $\frac{1}{3^{-5}}$ .

Question.64

The value for  $(-7)^6 + 7^6$  is \_\_\_\_\_.

Solution.

Using law of exponents,  $a^m + a^n = (a)^{m-n}$

[ $\because a$  is non-zero integer]

$$\therefore (-7)^6 + 7^6 = (7)^6 + (7)^6 \quad [(-a^m) = (a^m), \text{ if } m \text{ is an even number}]$$
$$= (7)^{6-6} = (7)^0 = 1 \quad [\because a^0 = 1]$$

$$\text{Hence, } (-7)^6 + 7^6 = 1$$

Question.65

The value of  $[1^{-2} + 2^{-2} + 3^{-2}] \times 6^2$  is \_\_\_\_\_.

Solution.

Using law of exponents,  $a^{-m} = \frac{1}{a^m}$

[ $\because a$  is non-zero integer]

$$\therefore [1^{-2} + 2^{-2} + 3^{-2}] \times 6^2 = \left[ \frac{1}{1^2} + \frac{1}{2^2} + \frac{1}{3^2} \right] \times 6^2 = \left[ 1 + \frac{1}{4} + \frac{1}{9} \right] \times 6^2$$
$$= \left( \frac{36 + 9 + 4}{36} \right) \times 6^2$$
$$= \left( \frac{49}{36} \right) \times 6^2 = \left( \frac{7}{6} \right)^2 \times 6^2 = (7)^2 \times 6^{-2} \times 6^2$$
$$= (7)^2 \times 6^{2-2} = (7)^2 \times 6^0 = 49 \quad [a^0 = 1]$$

$$\text{Hence, } [1^{-2} + 2^{-2} + 3^{-2}] \times 6^2 = 49$$

True / False

In questions 66 to 90, state whether the given statements are True or False.

Question.66

The multiplicative inverse of  $(-4)^{-2}$  is  $(4)^{-2}$ .

Solution.

**False**

$a$  is called the multiplicative inverse of  $b$ , if  $a \times b = 1$ .

$$\text{Put } b = (-4)^{-2}$$

$$\therefore a \times (-4)^{-2} = 1$$

$$\Rightarrow a = \frac{1}{(-4)^{-2}} = (-4)^2$$

$$\left[ \because a^{-m} = \frac{1}{a^m} \right]$$

Question.67

The multiplicative inverse of  $\left(\frac{3}{2}\right)^2$  is not equal to  $\left(\frac{2}{3}\right)^2$ .

Solution.

**True**

$a$  is called the multiplicative inverse of  $b$ , if  $a \times b = 1$ .

$$\text{Put } b = \left(\frac{3}{2}\right)^2$$

$$\text{So, } a \times \left(\frac{3}{2}\right)^2 = 1 \Rightarrow a = \left(\frac{3}{2}\right)^{-2}$$

Question.68

$$10^{-2} = \frac{1}{100}$$

Solution.

**True**

Using law of exponents,  $a^{-m} = \frac{1}{a^m}$

[ $\because a$  is non-zero integer]

$$\therefore 10^{-2} = \frac{1}{10^2} = \frac{1}{10 \times 10} = \frac{1}{100}$$

[ $\because 10^2 = 10 \times 10$ ]

Question.69  $24.58 = 2 \times 10 + 4 \times 1 + 5 \times 10 + 8 \times 100$

Solution. False

$$\text{RHS} = 2 \times 10 + 4 \times 1 + 5 \times 10 + 8 \times 100 = 20 + 4 + 50 + 800 = 874 \quad \text{LHS} \neq \text{RHS}$$

Question.70  $329.25 = 3 \times 10^2 + 2 \times 10^1 + 9 \times 10^0 + 2 \times 10^{-1} + 5 \times 10^{-2}$

Solution.

**True**

$$\text{RHS} = 3 \times 10^2 + 2 \times 10^1 + 9 \times 10^0 + 2 \times 10^{-1} + 5 \times 10^{-2}$$

$$= 3 \times 10 \times 10 + 2 \times 10 + 9 \times 1 + \frac{2}{10} + \frac{5}{10 \times 10}$$

[ $\because 10^0 = 1$ ]

$$= 300 + 20 + 9 + 0.2 + 0.05 = 329.25$$

$\therefore \text{LHS} = \text{RHS}$

Question.71

$$(-5)^{-2} \times (-5)^{-3} = (-5)^{-6}$$

Solution.

**False**

$$\text{LHS} = (-5)^{-2} \times (-5)^{-3}$$

Using law of exponents,  $a^m \times a^n = (a)^{m+n}$

[ $\because a$  is non-zero integer]

$$\therefore (-5)^{-2} \times (-5)^{-3} = (-5)^{-2-3} = (-5)^{-5}$$

$\text{LHS} \neq \text{RHS}$

Question.72

$$(-4)^{-4} \times (4)^{-1} = (4)^5$$

Solution.

**False**

$$\text{LHS} = (-4)^{-4} \times (4)^{-1}$$

Using law of exponents,  $a^m \times a^n = (a)^{m+n}$

[ $\because a$  is non-zero integer]

$$\therefore (-4)^{-4} \times (4)^{-1} = (4)^{-4} \times (4)^{-1}$$

$$= (4)^{-4-1}$$

$$= (4)^{-5}$$

$\text{LHS} \neq \text{RHS}$

Question.73

$$\left(\frac{2}{3}\right)^{-2} \times \left(\frac{2}{3}\right)^{-5} = \left(\frac{2}{3}\right)^{10}$$

Solution.

**False**

$$\text{LHS} = \left(\frac{2}{3}\right)^{-2} \times \left(\frac{2}{3}\right)^{-5}$$

Using law of exponents,  $a^m \times a^n = (a)^{m+n}$

[ $\because$  a is non-zero integer]

$$\therefore \left(\frac{2}{3}\right)^{-2} \times \left(\frac{2}{3}\right)^{-5} = \left(\frac{2}{3}\right)^{-2-5} = \left(\frac{2}{3}\right)^{-7}$$

LHS  $\neq$  RHS

Question. 74  $5^0 = 5$

Solution.

**False**

$$\text{LHS} = 5^0$$

Using law of exponents,  $a^0 = 1$

[ $\because$  a is non-zero integer]

$$\therefore 5^0 = 1$$

LHS  $\neq$  RHS

Question. 75  $(-2)^0 = 2$

Solution.

**False**

$$\text{LHS} = (-2)^0$$

Using law of exponents,  $a^0 = 1$

[ $\because$  a is non-zero integer]

$$\therefore (-2)^0 = 1$$

LHS  $\neq$  RHS

Question.76

$$\left(-\frac{8}{2}\right)^0 = 0$$

Solution.

**False**

$$\text{LHS} = \left(-\frac{8}{2}\right)^0$$

Using law of exponents,  $a^0 = 1$

[ $\because$  a is non-zero integer]

$$\therefore \left(-\frac{8}{2}\right)^0 = 1$$

LHS  $\neq$  RHS

Question. 77  $(-6)^0 = -1$

Solution.

**False**

$$\text{LHS} = (-6)^0$$

Using law of exponents,  $a^0 = 1$

[ $\because$  a is non-zero integer]

$$\therefore (-6)^0 = 1$$

LHS  $\neq$  RHS

Question. 78

$$(-7)^{-4} \times (-7)^2 = (-7)^{-2}$$

Solution.

**True**

$$\text{LHS} = (-7)^{-4} \times (-7)^2$$

Using law of exponents,  $a^m \times a^n = (a)^{m+n}$  [ $\because a$  is non-zero integer]

$$\therefore (-7)^{-4} \times (-7)^2 = (-7)^{-4+2} \\ = (-7)^{-2}$$

LHS = RHS

Question. 79

The value of  $\frac{1}{4^{-2}}$  is equal to 16.

Solution.

**True**

Using law of exponents,  $a^{-m} = \frac{1}{a^m}$  [ $\because a$  is non-zero integer]

$$\therefore \frac{1}{4^{-2}} = 4^2 = 4 \times 4 = 16$$

Question. 80

The expression for  $4^{-3}$  as a power with the base 2 is  $2^6$ .

Solution.

**False**

Using law of exponents,  $a^{-m} = \frac{1}{a^m}$

$$\therefore 4^{-3} = \frac{1}{4^3} = \frac{1}{(2^2)^3} = \frac{1}{2^6}$$
 [ $\because 2 \times 2 = 4, (a^m)^n = (a)^{mn}$ ]

Question. 81

$$a^p \times b^q = (ab)^{pq}$$

Solution.

**False**

$$\text{RHS} = (ab)^{pq}$$

Using law of exponents,  $(ab)^m = a^m \times b^m$  [ $\because a$  is non-zero integer]

$$\therefore (ab)^{pq} = (a)^{pq} \times (b)^{pq}$$

LHS  $\neq$  RHS

Question. 82

$$\frac{x^m}{y^n} = \left(\frac{y}{x}\right)^{-m}$$

Solution.

**True**

$$\text{RHS} = \left(\frac{y}{x}\right)^{-m}$$

Using laws of exponents,  $\left(\frac{a}{b}\right)^m = \frac{a^m}{b^m}$  and  $a^{-m} = \frac{1}{a^m}$  [ $\because a$  and  $b$  are non-zero integers]

$$\therefore \left(\frac{y}{x}\right)^{-m} = \frac{y^{-m}}{x^{-m}} = \frac{x^m}{y^m}$$

LHS = RHS

Question. 83

$$a^m = \frac{1}{a^{-m}}$$

Solution.

**True**

Using law of exponents,

$$a^m = \frac{1}{a^{-m}}$$

LHS = RHS

Question. 84

The exponential form for  $(-2)^4 \times \left(\frac{5}{2}\right)^4$  is  $5^4$ .

Solution.

Using laws of exponents,  $a^m \div a^n = (a)^{m-n}$  and  $\left(\frac{a}{b}\right)^m = \frac{a^m}{b^m}$

[ $\because$  a and b are non-zero integers]

$$\begin{aligned} \therefore (-2)^4 \times \left(\frac{5}{2}\right)^4 &= (2)^4 \times \frac{(5)^4}{(2)^4} = (2)^{4-4} \times 5^4 \\ &= 2^0 \times 5^4 = 5^4 \quad [\because (-a^m) = (a^m), \text{ if } m \text{ is an even number}] \end{aligned}$$

Question.85 The standard form for 0.000037 is  $3.7 \times 10^{-5}$

Solution. True

For standard form,  $0.000037 = 0.37 \times 10^{-4} = 3.7 \times 10^{-5}$

Question. 86 The standard form for 203000 is  $2.03 \times 10^5$ .

Solution. True

For standard form,  $203000 = 203 \times 10 \times 10 \times 10 = 203 \times 10^3$   
 $= 2.03 \times 10^2 \times 10^3 = 2.03 \times 10^5$

Question. 87 The usual form for  $2 \times 10^{-2}$  is not equal to 0.02.

Solution.

**False**

$$\begin{aligned} \text{For usual form, } 2 \times 10^{-2} &= 2 \times \frac{1}{10^2} \\ &= \frac{2}{100} = 0.02 \end{aligned}$$

$$\left[ \because a^{-m} = \frac{1}{a^m} \right]$$

Question. 88 The value of  $5^{-2}$  is equal to 25.

Solution. False

**False**

Using law of exponents,  $a^{-m} = \frac{1}{a^m}$

[ $\because$  a is non-zero integer]

$$\therefore 5^{-2} = \frac{1}{5^2} = \frac{1}{25}$$

Question. 89 Large numbers can be expressed in the standard form by using positive exponents.

Solution. True

e.g.  $2360000 = 236 \times 10 \times 10 \times 10 \times 10 = 236 \times 10^4$   
 $= 2.36 \times 10^4 \times 10^2 = 2.36 \times 10^6$

Question. 90

$$a^m \times b^m = (ab)^m$$

Solution.



**True**

$$\text{LHS} = a^m \times b^m = (a \times b)^m = (ab)^m$$

[by law of exponents]

Question. 91 Solve the following,

(i)  $100^{-10}$

(ii)  $2^{-2} \times 2^{-3}$

(iii)  $\left(\frac{1}{2}\right)^{-2} + \left(\frac{1}{2}\right)^{-3}$

Solution.

(i)  $100^{-10} = \frac{1}{100^{10}}$

$$[\because a^{-m} = \frac{1}{a^m}]$$

(ii)  $2^{-2} \times 2^{-3} = (2)^{-2-3} = (2)^{-5}$

$$[\because a^m \times a^n = (a)^{m+n}]$$

(iii)  $\left(\frac{1}{2}\right)^{-2} + \left(\frac{1}{2}\right)^{-3} = \left(\frac{1}{2}\right)^{-2+3} = \frac{1}{2}$

$$[\because a^m + a^n = (a)^{m+n}]$$

Question. 92 Express  $3^{-5} \times 3^{-4}$  as a power of 3 with positive exponent.

Solution.

Using laws of exponents,  $a^m \times a^n = (a)^{m+n}$  and  $a^{-m} = \frac{1}{a^m}$

[ $\because a$  is non-zero integer]

$$\therefore 3^{-5} \times 3^{-4} = (3)^{-5-4} = (3)^{-9} = \frac{1}{3^9}$$

Question. 93 Express  $16^{-2}$  as a power with the base 2.

Solution.

$\therefore 2 \times 2 \times 2 \times 2 = 16 = 2^4$

$$\therefore 16^{-2} = (2^4)^{-2} = (2)^{4 \times (-2)} = (2)^{-8}$$

[ $\because (a^m)^n = (a)^{mn}$ ]

Question. 94

Express  $\frac{27}{64}$  and  $\frac{-27}{64}$  as powers of a rational number.

Solution.

$\therefore 27 = 3 \times 3 \times 3 = 3^3, (-27) = (-3) \times (-3) \times (-3) = (-3)^3$

and  $64 = 4 \times 4 \times 4 = 4^3$

$$\therefore \frac{27}{64} = \frac{3^3}{4^3} = \left(\frac{3}{4}\right)^3 \text{ and } \frac{-27}{64} = \frac{(-3)^3}{(4)^3} = \left(\frac{-3}{4}\right)^3$$

Question. 95

Express  $\frac{16}{81}$  and  $\frac{-16}{81}$  as powers of a rational number.

Solution.

$\therefore 16 = 4 \times 4 = 4^2$

and  $81 = 9 \times 9 = 9^2$

$$\therefore \frac{16}{81} = \frac{(4)^2}{(9)^2} = \left(\frac{4}{9}\right)^2 \text{ and } \frac{-16}{81} = \frac{-(4)^2}{(9)^2} = -\left(\frac{4}{9}\right)^2$$

Question. 96 Express as a power of a rational number with negative exponent.

(a)  $\left(\left(\frac{-3}{2}\right)^{-2}\right)^{-3}$

(b)  $(2^5 + 2^8) \times 2^{-7}$

Solution.

(a) Using laws of exponents,  $(a^m)^n = (a)^{m \times n}$  and  $a^{-m} = \frac{1}{a^m}$  [ $\because a$  is non-zero integer]

$$\therefore \left( \left( \frac{-3}{2} \right)^{-2} \right)^{-3} = \left( \frac{-3}{2} \right)^{-2 \times (-3)} = \left( \frac{-3}{2} \right)^6 = \left( \frac{2}{3} \right)^{-6}$$

Using laws of exponents,  $a^m + a^n = a^{m+n}$

and  $a^m \times a^n = a^{m+n}$  [ $\because a$  is non-zero integer]

$$\therefore (2^5 + 2^8) \times 2^{-7} = (2^{5+8}) \times 2^{-7} = 2^{-3} \times 2^{-7} = 2^{-3-7} = 2^{-10}$$

Question. 97 Find the product of the cube of (-2) and the square of (+4).

Solution.

$$\therefore \text{Cube of } (-2) = (-2)^3$$

$$\text{and square of } (+4) = (+4)^2$$

$$\therefore \text{The product} = (-2)^3 \times (4)^2 = (-8) \times 16 = -128$$

Question.98 Simplify

$$(i) \left( \frac{1}{4} \right)^{-2} + \left( \frac{1}{2} \right)^{-2} + \left( \frac{1}{3} \right)^{-2} \quad (ii) \left( \left( \frac{-2}{3} \right)^{-2} \right)^3 \times \left( \frac{1}{3} \right)^{-4} \times 3^{-1} \times \frac{1}{6}$$

$$(iii) \frac{49 \times z^{-3}}{7^{-3} \times 10 \times z^{-5}} \quad (z \neq 0) \quad (iv) (2^5 + 2^8) \times 2^{-7}$$

Solution.

(i) Using law of exponents,  $a^{-m} = \frac{1}{a^m}$  [ $\because a$  is non-zero integer]

$$\therefore \left( \frac{1}{4} \right)^{-2} + \left( \frac{1}{2} \right)^{-2} + \left( \frac{1}{3} \right)^{-2} = (4)^2 + (2)^2 + (3)^2 = 16 + 4 + 9 = 29$$

(ii) Using laws of exponents,  $(a^m)^n = (a)^{m \times n}$ ,  $a^{-m} = \frac{1}{a^m}$ ,  $a^m \times a^n = a^{m+n}$  and  $a^m + a^n = a^{m+n}$

[ $\because a$  is non-zero integer]

$$\therefore \left( \left( \frac{-2}{3} \right)^{-2} \right)^3 \times \left( \frac{1}{3} \right)^{-4} \times 3^{-1} \times \frac{1}{6} = \left( \frac{-2}{3} \right)^{(-2) \times 3} \times (3)^4 \times \frac{1}{3} \times \frac{1}{6}$$

$$= \left( \frac{-2}{3} \right)^{-6} \times 3^4 \times \frac{1}{3} \times \frac{1}{2 \times 3} \quad [\because 6 = 2 \times 3]$$

$$= \left( \frac{3}{-2} \right)^6 \times 3^4 \times \frac{1}{3 \times 2 \times 3} = \frac{(3)^6}{(-2)^6} \times 3^4 \times \frac{1}{2^1 \times 3^2}$$

$$= \frac{(3)^{6+4}}{(2)^{6+1} \times 3^2} \quad [(-a^m) = a^m, \text{ if } m \text{ is an even number}]$$

$$= \frac{(3)^{10}}{2^7 \times 3^2} = \frac{3^{10-2}}{2^7} = \frac{3^8}{2^7}$$

$$(iii) \frac{49 \times z^{-3}}{7^{-3} \times 10 \times z^{-5}} = \frac{(7)^2 \times z^{-3}}{7^{-3} \times 10 \times z^{-5}} = \frac{(7)^{2+3} \times z^{-3+5}}{10} \quad [\because a^m + a^n = (a)^{m+n}]$$

$$= \frac{(7)^5 z^2}{10} = \frac{7^5}{10} z^2$$

(iv) Using laws of exponents,  $a^m + a^n = (a)^{m+n}$  and  $a^m \times a^n = (a)^{m+n}$

[ $\because a$  is non-zero integer]

$$\therefore (2^5 + 2^8) \times (2)^{-7} = (2)^{5+8} \times (2)^{-7}$$

$$= (2)^{-3} \times (2)^{-7}$$

$$= (2)^{-3-7} = (2)^{-10} = \frac{1}{2^{10}} = \frac{1}{1024} \quad \left[ \because a^{-m} = \frac{1}{a^m} \right]$$

Question. 99 Find the value of x, so that

$$(i) \left( \frac{5}{3} \right)^{-2} \times \left( \frac{5}{3} \right)^{-14} = \left( \frac{5}{3} \right)^{8x} \quad (ii) (-2)^3 \times (-2)^{-6} = (-2)^{2x-1}$$

$$(iii) (2^{-1} + 4^{-1} + 6^{-1} + 8^{-1})^x = 1$$

Solution.

(i) We have,  $\left(\frac{5}{3}\right)^{-2} \times \left(\frac{5}{3}\right)^{-14} = \left(\frac{5}{3}\right)^{8x}$

Using law of exponents,  $a^m \times a^n = (a)^{m+n}$  [ $\because a$  is non-zero integer]

Then,  $\left(\frac{5}{3}\right)^{-2} \times \left(\frac{5}{3}\right)^{-14} = \left(\frac{5}{3}\right)^{8x}$

$\Rightarrow \left(\frac{5}{3}\right)^{-2-14} = \left(\frac{5}{3}\right)^{8x}$

$\Rightarrow \left(\frac{5}{3}\right)^{-16} = \left(\frac{5}{3}\right)^{8x}$

On comparing both sides, we get

$$16 = 8x$$

$\Rightarrow x = -2$

(ii) We have  $(-2)^3 \times (-2)^{-6} = (-2)^{2x-1}$

Using law of exponents,  $a^m \times a^n = (a)^{m+n}$  [ $\because a$  is non-zero integer]

Then,  $(-2)^3 \times (-2)^{-6} = (-2)^{2x-1}$

$\Rightarrow (-2)^{3-6} = (-2)^{2x-1}$

$\Rightarrow (-2)^{-3} = (-2)^{2x-1}$

On comparing both sides, we get

$$3 = 2x - 1$$

$\Rightarrow 2x = -2 \Rightarrow x = -1$

(iii) We have,  $(2^{-1} + 4^{-1} + 6^{-1} + 8^{-1})^x = 1$

Using law of exponents,  $a^{-m} = \frac{1}{a^m}$  [ $\because a$  is non-zero integer]

Then,  $\left(\frac{1}{2} + \frac{1}{4} + \frac{1}{6} + \frac{1}{8}\right)^x = 1$

$\Rightarrow \left(\frac{12 + 6 + 4 + 3}{24}\right)^x = 1$  [ $\because$  LCM of 2, 4, 6 and 8 = 24]

$\Rightarrow \left(\frac{25}{24}\right)^x = 1$

This can be possible only if  $x = 0$ . Since,  $a^0 = 1$  [law of exponents]

Question. 100 Divide 293 by 1000000 and express the result in standard form.

Solution.

$\because 1000000 = 10^6$

$\because \frac{293}{10^6} = 293 \times 10^{-6}$  [ $\because \frac{1}{a^m} = a^{-m}$ ]

$= 2.93 \times 10^{-6} \times 10^2 = 2.93 \times 10^{-4}$

Question. 101

Find the value of  $x^{-3}$ , if  $x = (100)^{1-4} + (100)^0$ .

Solution.

Given,  $x = (100)^{1-4} + (100)^0$

$\Rightarrow x = (100)^{-3} + (100)^0$

$\Rightarrow x = (100)^{-3-0}$  [ $\because a^m + a^n = (a)^{m+n}$ ]

$\Rightarrow x = (100)^{-3}$

So,  $x^{-3} = [(100)^{-3}]^{-3} = (100)^9$  [ $\because (a^m)^n = (a)^{mn}$ ]

Q. 102 By what number should we multiply  $(-29)^0$ , so that the product becomes  $(+29)^0$ .

Solution.

Let  $n$  be multiplied with  $(-29)^0$  to get  $(+29)^0$ .

So,  $x \times (-29)^0 = (29)^0$

$\Rightarrow x \times 1 = 1$

$[\because a^0 = 1]$

$\Rightarrow x = 1$

Question. 103 By what number should  $(-15)^{-1}$  be divided so that quotient may be equal to  $(-15)^{-1}$ ?

Solution.

Let  $(-15)^{-1}$  be divided by  $x$  to get quotient  $(-15)^{-1}$ .

So,  $\frac{(-15)^{-1}}{x} = (-15)^{-1}$

$\Rightarrow \frac{(-15)^{-1}}{(-15)^{-1}} = x$

$\Rightarrow x = (-15)^{-1+1}$

$[\because a^m \div a^n = (a)^{m-n}]$

$\Rightarrow x = (-15)^0 = 1$

$[\because a^0 = 1]$

Question.104 Find the multiplicative inverse of  $(-7)^2 \div (90)^{-1}$

Solution.

$a$  is called multiplicative inverse of  $b$ , if  $a \times b = 1$

We have,  $(-7)^{-2} \div (90)^{-1} = \frac{1}{(7)^2} \div \frac{1}{(90)^1} = \frac{1}{49} \div \frac{1}{90} = \frac{1}{49} \times \frac{90}{1} = \frac{90}{49}$

$[\because (-a)^m = a^m, \text{ if } m \text{ is an even number and } a^{-m} = \frac{1}{a^m}]$

Put  $b = \frac{90}{49}$

$\therefore a \times \frac{90}{49} = 1$

$\Rightarrow a = \frac{49}{90}$

Question.105

If  $5^{3x-1} + 25 = 125$ , find the value of  $x$ .

Solution.

Given,  $5^{3x-1} + 25 = 125$

$\therefore 25 = 5 \times 5 = 5^2$

and  $125 = 5 \times 5 \times 5 = 5^3$

$\therefore 5^{3x-1} + (5)^2 = (5)^3$

$\Rightarrow (5)^{3x-1-2} = 5^3$

$[\because a^m + a^n = (a)^{m+n}]$

$\Rightarrow 5^{3x-3} = (5)^3$

On comparing both sides, we get

$3x - 3 = 3$

$\Rightarrow 3x = 6$

$\Rightarrow x = 2$

Question.106 Write 390000000 in the standard form.

Solution.

For standard form  $390000000 = 39 \times 10 \times 10 \times 10 \times 10 \times 10 \times 10 \times 10$

$= 39 \times 10^7 = 3.9 \times 10^7 \times 10^1$

$= 3.9 \times 10^8$

$[\because a^m \times a^n = (a)^{m+n}]$

Question. 107 Write 0.000005678 in the standard form.

Solution.

For standard form,  $0.000005678 = 0.5678 \times 10^{-5} = 5.678 \times 10^{-5} \times 10^{-1} = 5.678 \times 10^{-6}$  Hence,

$5.678 \times 10^{-6}$  is the standard form of 0.000005678.

Question.108 Express the product of  $3.2 \times 10^6$  and  $4.1 \times 10^{-1}$  in the standard form.

Solution.

Product of  $3.2 \times 10^6$  and  $4.1 \times 10^{-1}$

$$\begin{aligned} &= (3.2 \times 10^6)(4.1 \times 10^{-1}) \\ &= (3.2 \times 4.1) \times 10^6 \times 10^{-1} \\ &= 13.12 \times 10^5 = 1.312 \times 10^6 \times 10^1 \quad [\because a^m \times a^n = a^{m+n}] \\ &= 1.312 \times 10^7 \end{aligned}$$

Question.109

Express  $\frac{1.5 \times 10^6}{2.5 \times 10^{-4}}$  in the standard form.

Solution.

$$\begin{aligned} \text{Given, } \frac{1.5 \times 10^6}{2.5 \times 10^{-4}} &= \frac{15}{25} \times 10^{6+4} && [\because a^m \div a^n = (a)^{m-n}] \\ &= \frac{3}{5} \times 10^{10} = 0.6 \times 10^{10} \\ &= 6 \times 10^9 \times 10^{-1} = 6 \times 10^8 && [\because a^m \times a^n = a^{m+n}] \end{aligned}$$

Question. 110 Some migratory birds travel as much as 15000 km to escape the extreme climatic conditions at home. Write the distance in metres using scientific notation.

Solution.

$$\begin{aligned} \text{Total distance travelled by migratory bird} &= 15000 \text{ km} \\ &= 15000 \times 1000 \text{ m} && [\because 1 \text{ km} = 1000 \text{ m}] \\ &= 15000000 \text{ m} \\ &= 15 \times 10^6 \text{ m} \end{aligned}$$

Scientific notation of  $15 \times 10^6 = 1.5 \times 10^7 \text{ m}$

Question. 111 Pluto is 5913000000 m from the Sun. Express this in the standard form.

Solution.

$$\begin{aligned} \text{Distance between Pluto and Sun} &= 5913000000 \\ \text{Standard form of } 5913000000 &= 5913 \times 10^6 \\ &= 5.913 \times 10^3 \times 10^3 \\ &= 5.913 \times 10^6 && [\because a^m \times a^n = (a)^{m+n}] \end{aligned}$$

Question. 112 Special balances can weigh something as 0.00000001 gram. Express this number in the standard form.

Solution.

$$\begin{aligned} \text{Weight} &= 0.00000001 \text{ g} \\ \text{Standard form of } 0.00000001 \text{ g} &= 01 \times 10^{-7} \text{ g} \\ &= 1 \times 10^{-7} \times 10^{-1} \text{ g} \\ &= 1.0 \times 10^{-8} \text{ g} && [\because a^m \times a^n = (a)^{m+n}] \end{aligned}$$

Question. 113 A sugar factory has annual sales of 3 billion 720 million kilograms of sugar. Express this number in the standard form.

Solution.

$$\begin{aligned} \text{Annual sales of a sugar factory} &= 3 \text{ billion } 720 \text{ million kilograms} = 3720000 \text{ kg} \\ \text{Standard form of } 3720000 &= 372 \times 10 \times 10 \times 10 \times 10 = 372 \times 10^4 \text{ kg} \\ &= 3.72 \times 10^2 \times 10^4 = 3.72 \times 10^6 \text{ kg} && [\because a^m \times a^n = (a)^{m+n}] \end{aligned}$$



(g) Given, 2 yr =  $2 \times 365$  days [∵ 1 yr = 365 days approx.]  
 $= 2 \times 365 \times 24$  h [∵ 1 day = 24 h]  
 $= 2 \times 365 \times 24 \times 60$  min [∵ 1 h = 60 min]  
 $= 2 \times 365 \times 24 \times 60 \times 60$  s [∵ 1 min = 60 s]  
 $= 63072000$  s

Standard form of 63072000 =  $63072 \times 10 \times 10 \times 10 = 63072 \times 10^3$   
[∵  $a^m \times a^n = (a)^{m+n}$ ]  
 $= 6.3072 \times 10^3 \times 10^4 = 6.3072 \times 10^7$  s

(h) Given, 5 hec =  $5 \times 10000$  m<sup>2</sup> [∵ 1 hec = 10000 m<sup>2</sup>]  
 $= 5 \times 10000 \times 100 \times 100$  cm<sup>2</sup> [∵ 1 m = 100 cm]

Standard form of  $5 \times 10000 \times 100 \times 100$  cm<sup>2</sup>  
 $= 5 \times 10 \times 10 \times 10 \times 10 \times 10 \times 10 \times 10 \times 10$   
 $= 5 \times 10^8$  cm<sup>2</sup> [∵  $a^m \times a^n = (a)^{m+n}$ ]

Question.116

Find  $x$ , so that  $\left(\frac{2}{9}\right)^3 \times \left(\frac{2}{9}\right)^{-6} = \left(\frac{2}{9}\right)^{2x-1}$ .

Solution.

Given,  $\left(\frac{2}{9}\right)^3 \times \left(\frac{2}{9}\right)^{-6} = \left(\frac{2}{9}\right)^{2x-1}$

Using law of exponents,  $a^m \times a^n = (a)^{m+n}$  [∵  $a$  is non-zero integer]

Then,  $\left(\frac{2}{9}\right)^{3-6} = \left(\frac{2}{9}\right)^{2x-1}$

$\Rightarrow \left(\frac{2}{9}\right)^{-3} = \left(\frac{2}{9}\right)^{2x-1}$

On comparing, we get

$-3 = 2x - 1$   
 $\Rightarrow -2 = 2x$   
 $\Rightarrow x = -1$

Question.117

By what number should  $\left(\frac{-3}{2}\right)^{-3}$  be divided so that the quotient may be  $\left(\frac{4}{27}\right)^{-2}$ ?

Solution.

Let  $\left(\frac{-3}{2}\right)^{-3}$  be divided by  $x$  to get  $\left(\frac{4}{27}\right)^{-2}$  as quotient.

Then,  $\left(\frac{-3}{2}\right)^{-3} \div x = \left(\frac{4}{27}\right)^{-2}$

$\Rightarrow x = \left(\frac{-3}{2}\right)^{-3} \div \left(\frac{4}{27}\right)^{-2} = \left(\frac{-3}{2}\right)^{-3} \times \frac{(2)^{-4}}{(3)^{-6}}$   
 $= \left(\frac{-3}{2}\right)^{-3} \times \frac{(3)^{-6}}{(2)^{-4}}$  [∵  $a^m \times a^n = a^{m+n}$ ]  
 $= \frac{(-3)^{-3} \times (3)^{-6}}{2^{-3} \times 2^{-4}} = \frac{3^{-9}}{2^{-7}}$   
 $= \frac{2^7}{3^9}$  [∵  $a^{-m} = \frac{1}{a^m}$  and  $(a^m)^n = (a)^{mn}$ ]

In questions 118 and 119, find the value of  $n$ .

Question.118

$\frac{6^6}{6^{-2}} = 6^3$

Solution.

$$\text{Given, } \frac{6^n}{6^{-2}} = 6^3$$

$$\text{Using law of exponents, } \frac{6^n}{6^{-2}} = 6^3$$

[ $\because a$  is non-zero integer]

$$\Rightarrow 6^{n+2} = 6^3$$

[ $\because a^m \times a^n = a^{m+n}$ ]

On comparing both sides, we get

$$n+2=3 \Rightarrow n=1$$

Question.119

$$\frac{2^n \times 2^5}{2^{-3}} = 2^{18}$$

Solution.

$$\text{Given, } \frac{2^n \times 2^5}{2^{-3}} = 2^{18}$$

$$\text{Using law of exponents, } a^{-m} = \frac{1}{a^m}$$

[ $\because a$  is non-zero integer]

$$\Rightarrow 2^n \times 2^5 \times 2^3 = 2^{18}$$

$$\Rightarrow 2^{n+8} = 2^{18}$$

[ $\because a^m \times a^n = a^{m+n}$ ]

On comparing both sides, we get

$$n+8=18 \Rightarrow n=9$$

[ $\because a^m + a^n = (a)^{m+n}$ ]

Question.120

$$\frac{125 \times x^{-3}}{5^{-3} \times 25 \times x^{-6}}$$

Solution.

$$\text{Using laws of exponents, } a^m + a^n = (a)^{m+n} \text{ and } a^{-m} = \frac{1}{a^m}$$

[ $\because a$  is non-zero integer]

$$\therefore \frac{125 \times x^{-3}}{5^{-3} \times 25 \times x^{-6}} = (5)^3 \times 5^3 \times 5^{-2} \times x^{-3} \times x^6$$

[ $\because 125 = 5 \times 5 \times 5$   
and  $25 = 5 \times 5$ ]

$$= 5^4 \times x^3$$

$$= 5 \times 5 \times 5 \times 5 \times x^3$$

$$= 625 x^3$$

[ $\because a^m \times a^n = a^{m+n}$ ]

Question.121

$$\frac{16 \times 10^2 \times 64}{2^4 \times 4^2}$$

Solution.

$$\text{Using laws of exponents, } a^m + a^n = (a)^{m+n} \text{ and } a^m \times a^n = a^{m+n}$$

[ $\because a$  is non-zero integer]

$$\therefore \frac{16 \times 10^2 \times 64}{2^4 \times 4^2} = (4)^2 \times 10^2 \times 2^{-4} \times (4)^3 \times 4^{-2}$$

[ $\because 64 = 4 \times 4 \times 4$   
and  $16 = 4 \times 4$ ]

$$= (4)^3 \times 10^2 \times 2^{-4}$$

$$= (2^2)^3 \times 10^2 \times 2^{-4}$$

$$= 2^6 \times 10^2 \times 2^{-4}$$

$$= 2^2 \times 10^2 = 4 \times 100 = 400$$

[ $\because 2^2 = 4$ ]

Question.122

$$\text{If } \frac{5^m \times 5^3 \times 5^{-2}}{5^{-5}} = 5^{12}, \text{ then find } m.$$

Solution.



Given,  $\frac{5^m \times 5^3 \times 5^{-2}}{5^{-5}} = 5^{12}$

Using laws of exponents,  $a^m \times a^n = (a)^{m+n}$  and  $a^{-m} = \frac{1}{a^m}$  [ $\because a$  is non-zero integer]

Then,  $5^m \times 5^3 \times 5^{-2} \times 5^5 = 5^{12}$

$\Rightarrow 5^m \times 5^8 \times 5^{-2} = 5^{12}$

$\Rightarrow 5^m \times 5^6 = 5^{12}$

$\Rightarrow 5^{m+6} = 5^{12}$  [ $\because a^m \times a^n = a^{m+n}$ ]

On comparing both sides, we get

$m + 6 = 12$

$\Rightarrow m = 6$

**Question.123** A new born bear weights 4 kg. How many kilograms might a five year old bear weight if its weight increases by the power of 2 in 5 yr?

**Solution.**

Weight of new born bear = 4 kg

Weight increases by the power of 2 in 5 yr.

Weight of bear in 5 yr =  $(4)^2 = 16$  kg

**Question.124** The cell of a bacteria doubles in every 30 min. A scientist begins with a single cell. How many cells will be thereafter (a) 12 h (b) 24 h ?

**Solution.**

The cell of a bacteria in every 30 min = 2 [ $\because 1 + 1 = 2$  in 30 min]

So, cell of a bacteria in 1 h =  $2^2$  [ $\because 2 + 2$  in 1 h]

(a) Cell of a bacteria in 12 h =  $2^2 \times 2^2 \times 2^2 \times 2^2 \times 2^2 \times 2^2 \times 2^2 \times 2^2 \times 2^2 \times 2^2 \times 2^2 \times 2^2$   
 $= 2^{24}$  [ $\because a^m \times a^n = a^{m+n}$ ]

(b) Similarly, bacteria in 24 h =  $2^{24} \times 2^{24} = 2^{24+24} = 2^{48}$  [ $\because a^m \times a^n = a^{m+n}$ ]

**Question.125** Planet A is at a distance of  $9.35 \times 10^6$  km from Earth and planet B is  $6.27 \times 10^7$  km from Earth. Which planet is nearer to Earth?

**Solution.**

Distance between planet A and Earth =  $9.35 \times 10^6$  km Distance between planet B and Earth =  $6.27 \times 10^7$  km

For finding difference between above two distances, we have to change both in same exponent of 10, i.e.  $9.35 \times 10^6 = 0.935 \times 10^7$ , clearly  $6.27 \times 10^7$  is greater.

So, planet A is nearer to Earth.

**Question.126** The cells of a bacteria double itself every hour. How many cells will be there after 8 h, if initially we start with 1 cell. Express the answer in powers.

**Solution.**

The cell of a bacteria double itself every hour =  $1 + 1 = 2 = 2^1$

Since, the process started with 1 cell.

$\therefore$  The total number of cell in 8 h =  $2^1 \times 2^1 \times 2^1 \times 2^1 \times 2^1 \times 2^1 \times 2^1 \times 2^1$   
 $= 2^{1+1+1+1+1+1+1+1} = 2^8$  [ $\because a^m \times a^n = (a)^{m+n}$ ]

**Question. 127** An insect is on the 0 point of a number line, hopping towards 1. She covers half the distance from her current location to 1 with each hop.

So, she will be at  $1/2$  after one hop,  $3/4$  after two hops and so on.

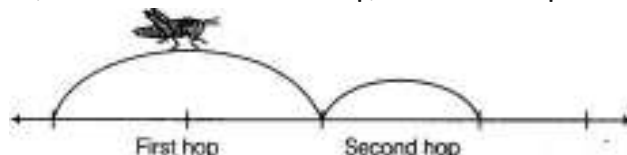

(a) Make a table showing the insect's Location for the first 10 hops.

(b) Where will the insect be after n hops?

(c) Will the insect ever get to 1? Explain.

Solution.

(a) On the basis of given information in the question, we can arrange the following table which shows the insect's location for the first 10 hops.

Number of hops	Distance Covered	Distance left	Distance covered
1.	$\frac{1}{2}$	$\frac{1}{2}$	$1 - \frac{1}{2}$
2.	$\frac{1}{2}\left(\frac{1}{2}\right) + \frac{1}{2}$	$\frac{1}{4}$	$1 - \frac{1}{4}$
3.	$\frac{1}{2}\left(\frac{1}{4}\right) + \frac{3}{4}$	$\frac{1}{8}$	$1 - \frac{1}{8}$
4.	$\frac{1}{2}\left(\frac{1}{8}\right) + \frac{7}{8}$	$\frac{1}{16}$	$1 - \frac{1}{16}$
5.	$\frac{1}{2}\left(\frac{1}{16}\right) + \frac{15}{16}$	$\frac{1}{32}$	$1 - \frac{1}{32}$
6.	$\frac{1}{2}\left(\frac{1}{32}\right) + \frac{31}{32}$	$\frac{1}{64}$	$1 - \frac{1}{64}$
7.	$\frac{1}{2}\left(\frac{1}{64}\right) + \frac{63}{64}$	$\frac{1}{128}$	$1 - \frac{1}{128}$
8.	$\frac{1}{2}\left(\frac{1}{128}\right) + \frac{127}{128}$	$\frac{1}{256}$	$1 - \frac{1}{256}$
9.	$\frac{1}{2}\left(\frac{1}{256}\right) + \frac{255}{256}$	$\frac{1}{512}$	$1 - \frac{1}{512}$
10.	$\frac{1}{2}\left(\frac{1}{512}\right) + \frac{511}{512}$	$\frac{1}{1024}$	$1 - \frac{1}{1024}$

(b) If we see the distance covered in each hops

$$\text{Distance covered in 1st hop} = 1 - \frac{1}{2}$$

$$\text{Distance covered in 2nd hops} = 1 - \frac{1}{4}$$

$$\text{Distance covered in 3rd hops} = 1 - \frac{1}{8}$$

⋮            ⋮            ⋮

$$\text{Distance covered in } n \text{ hops} = 1 - \left(\frac{1}{2}\right)^n$$

(c) No, because for reaching 1  $\left(\frac{1}{2}\right)^n$  has to be zero for some finite n which is not possible.

Question. 128 Predicting the ones digit, copy and complete this table and answer the questions that follow.

**Powers Table**

$x$	$1^x$	$2^x$	$3^x$	$4^x$	$5^x$	$6^x$	$7^x$	$8^x$	$9^x$	$10^x$
1	1	2								
2	1	4								
3	1	8								
4	1	16								
5	1	32								
6	1	64								
7	1	128								
8	1	256								
Ones digits of the powers	1	2,4,6,8								

(a) Describe patterns you see in the ones digits of the powers.

(b) Predict the ones digit in the following.

(i)  $4^{12}$

(ii)  $9^{20}$

(iii)  $3^{17}$

(iv)  $5^{100}$

(v)  $10^{500}$

(c) Predict the ones digit in the following.

(i)  $31^{10}$

(ii)  $12^{10}$

(iii)  $17^{21}$

(iv)  $29^{10}$

**Solution.**

(a) On the basis of given pattern in  $1^x$  and  $2^x$ , we can make more patterns for  $3^x, 4^x, 5^x, 6^x, 7^x, 8^x, 9^x, 10^x$ .

Thus, we have following table which shows all details about the patterns.

$x$	$1^x$	$2^x$	$3^x$	$4^x$	$5^x$	$6^x$	$7^x$	$8^x$	$9^x$	$10^x$
1	1	2	3	4	5	6	7	8	9	10
2	1	4	9	16	25	36	49	64	81	100
3	1	8	27	64	125	216	343	512	729	1000
4	1	16	81	256	625	1296	2401	4096	6561	10000
5	1	32	243	1024	3125	7776	16807	32768	59049	100000
6	1	64	729	4096	15625	46656	117649	262144	531441	1000000
7	1	128	2187	16384	78125	279936	823543	2097152	4782969	10000000
8	1	256	6561	65536	390625	1679616	5764801	16777216	43046721	100000000
Ones digits of the powers	1	2,4,6,8	3,9,7,1	4,6	5	6	7,9,3,1	8,4,2,6	9,1	0

(b) (i) ones digit in  $4^{12}$  is 6.

(ii) ones digit in  $9^{20}$  is 1.

(ii) ones digit in  $3^{17}$  is 3.

(iv) ones digit in  $5^{100}$  is 5.

(v) ones digit in  $10^{500}$  is 0.

**Note** Follow the above given table

(c) (i) ones digit in  $31^{10}$  is 1.

(ii) ones digit in  $12^{10}$  is 4.

(iii) ones digit in  $17^{21}$  is 7.

(iv) ones digit in  $29^{10}$  is 1.

**Question. 129 Astronomy** The table shows the mass of the planets, the Sun and the Moon in our solar system.

Celestial Body	Mass (kg)	Mass (kg) Standard Notation
Sun	1,990,000,000,000,000,000,000,000,000	$1.99 \times 10^{30}$
Mercury	330,000,000,000,000,000,000,000	
Venus	4,870,000,000,000,000,000,000,000	
Earth	5,970,000,000,000,000,000,000,000	
Mars	642,000,000,000,000,000,000,000,000	
Jupiter	1,900,000,000,000,000,000,000,000,000	
Saturn	568,000,000,000,000,000,000,000,000	
Uranus	86,800,000,000,000,000,000,000,000	
Neptune	102,000,000,000,000,000,000,000,000	
Pluto	12,700,000,000,000,000,000,000,000	
Moon	79,500,000,000,000,000,000,000	

- (a) Write the mass of each planet and the Moon in scientific notation.  
 (b) Order the planets and the Moon by mass, from least to greatest.  
 (c) Which planet has about the same mass as Earth?

Solution.

- (a) Mass of each planet and Moon in scientific notation is given below:

Using law of exponents,  $a^m \times a^n = a^{m+n}$

$$\text{Sun} = 199 \times 10^{28} = 1.99 \times 10^{28} \times 10^2 = 1.99 \times 10^{30}$$

$$\text{Mercury} = 33 \times 10^{22} = 3.3 \times 10^{22} \times 10 = 3.3 \times 10^{23}$$

$$\text{Venus} = 487 \times 10^{22} = 4.87 \times 10^{22} \times 10^2 = 4.87 \times 10^{24}$$

$$\text{Earth} = 597 \times 10^{22} = 5.97 \times 10^{22} \times 10^2 = 5.97 \times 10^{24}$$

$$\text{Mars} = 642 \times 10^{27} = 6.42 \times 10^{27} \times 10^2 = 6.42 \times 10^{29}$$

$$\text{Jupiter} = 19 \times 10^{26} = 1.9 \times 10^{26} \times 10 = 1.9 \times 10^{27}$$

$$\text{Saturn} = 568 \times 10^{24} = 5.68 \times 10^{24} \times 10^2 = 5.68 \times 10^{26}$$

$$\text{Uranus} = 868 \times 10^{23} = 8.68 \times 10^{23} \times 10^2 = 8.68 \times 10^{25}$$

$$\text{Neptune} = 102 \times 10^{24} = 1.02 \times 10^{24} \times 10^2 = 1.02 \times 10^{26}$$

$$\text{Pluto} = 127 \times 10^{20} = 1.27 \times 10^{20} \times 10^2 = 1.27 \times 10^{22}$$

$$\text{Moon} = 795 \times 10^{20} = 7.95 \times 10^{20} \times 10^2 = 7.95 \times 10^{22}$$

- (b) Order of mass of all planets and Moon from least to greatest

Pluto < Moon < Mercury < Venus < Earth < Uranus < Neptune < Saturn < Jupiter < Mars

- (c) Venus has about the same mass as Earth.

Question. 130 Investigating Solar System The table shows the average distance from each planet in our solar system to the Sun.

Planet	Distance from Sun (km)	Distance from Sun (km) Standard Notation
Earth	149,600,000	$1.496 \times 10^8$
Jupiter	778,300,000	
Mars	227,900,000	
Mercury	57,900,000	
Neptune	4,497,000,000	
Pluto	5,900,000,000	
Saturn	1,427,000,000	
Uranus	2,870,000,000	
Venus	108,200,000	

Solution.

- (a) Scientific notation of distance from Sun to  
 Earth =  $149600000 = 1496 \times 10^5 = 1.496 \times 10^8$   
 Jupiter =  $149600000 = 1496 \times 10^5 = 1.496 \times 10^8$   
 Mars =  $227900000 = 2279 \times 10^5 = 2.279 \times 10^8$   
 Mercury =  $57900000 = 579 \times 10^5 = 5.79 \times 10^7$   
 Neptune =  $4497000000 = 4497 \times 10^6 = 4.497 \times 10^9$   
 Pluto =  $5900000000 = 59 \times 10^8 = 5.9 \times 10^9$   
 Saturn =  $1427000000 = 1427 \times 10^6 = 1.427 \times 10^9$   
 Uranus =  $2870000000 = 287 \times 10^7 = 2.87 \times 10^9$   
 Venus =  $108200000 = 1082 \times 10^5 = 1.082 \times 10^8$
- (b) Order of planet from closest to the Sun to farthest from the Sun is given by  
 Mercury < Venus < Earth < Mars < Jupiter < Saturn < Uranus < Neptune < Pluto

Question. 131 This table shows the mass of one atom for five chemical elements. Use it to answer the question given.

Elements	Mass of atom (kg)
Titanium	$7.95 \times 10^{-26}$
Lead	$3.44 \times 10^{-25}$
Silver	$1.79 \times 10^{-25}$
Lithium	$1.15 \times 10^{-26}$
Hydrogen	$1.674 \times 10^{-27}$

- (a) Which is the heaviest element?  
 (b) Which element is lighter, Silver or Titanium?  
 (c) List all the five elements in order from lightest to heaviest.

Solution.

Arrangement of masses of atoms in same power of 10 is given by

$$\text{Titanium} = 7.95 \times 10^{-26}$$

$$\text{Lead} = 34.4 \times 10^{-26}$$

$$\text{Silver} = 17.9 \times 10^{-26}$$

$$\text{Lithium} = 1.15 \times 10^{-26}$$

$$\text{Hydrogen} = 0.1674 \times 10^{-26}$$

Thus, we have

$$34.4 > 17.9 > 7.95 > 1.15 > 0.1674$$

- (a) Lead is the heaviest element.  
 (b) Silver =  $17.9 \times 10^{-26}$  and Titanium =  $7.95 \times 10^{-26}$ , so titanium is lighter.  
 (c) Arrangement of elements in order from lightest to heaviest is given by  
 Hydrogen < Lithium < Titanium < Silver < Lead

Question. 132 The planet Uranus is approximately 2,896,819,200,000 metres away from the Sun. What is this distance in standard form?

Solution.

Distance between the planet Uranus and the Sun is 2896819200000 m.

Standard form of 2896819200000 =  $28968192 \times 10 \times 10 \times 10 \times 10 \times 10$

$$= 28968192 \times 10^5 = 2.8968192 \times 10^{12} \text{ m}$$

Question. 133 An inch is approximately equal to 0.02543 metres. Write this distance in standard form.

Solution. Standard form of 0.02543 m =  $0.2543 \times 10^{-1} \text{ m} = 2.543 \times 10^{-2} \text{ m}$  Hence, standard form of 0.02543 is  $2.543 \times 10^{-2} \text{ m}$ .

Question. 134 The volume of the Earth is approximately  $7.67 \times 10^{-7}$  times the volume of the Sun. Express this figure in usual form.

**Solution.**

Given, volume of the Earth is  $7.67 \times 10^{-7}$  times the volume of the Sun.

Usual form of  $7.67 \times 10^{-7} = 0.000000767$

[∵ placing decimal 7 places towards the left of original position]

**Question.135** An electron's mass is approximately  $9.1093826 \times 10^{-31}$  kilograms. What is its mass in grams?

**Solution.**

Mass of electron =  $9.1093826 \times 10^{-31}$  kg

$$= 9.1093826 \times 10^{-31} \times 1000 \text{ g} \quad [\because 1 \text{ kg} = 1000 \text{ g}]$$

$$= 9.1093826 \times 10^{-31} \times 10^3 = 9.1093826 \times 10^{-28} \text{ g} \quad [\because a^m \times a^n = (a)^{m+n}]$$

**Question. 136** At the end of the 20th century, the world population was approximately  $6.1 \times 10^9$  people. Express this population in usual form. How would you say this number in words?

**Solution.**

Given, at the end of the 20th century, the world population was  $6.1 \times 10^9$  (approx). People population in usual form =  $6.1 \times 10^9 = 6100000000$  Hence, population in usual form was six thousand one hundred million.

**Question.137** While studying her family's history, Shikha discovers records of ancestors 12 generations back. She wonders how many ancestors she had in the past 12 generations. She starts to make a diagram to help her figure this out. The diagram soon becomes very complex

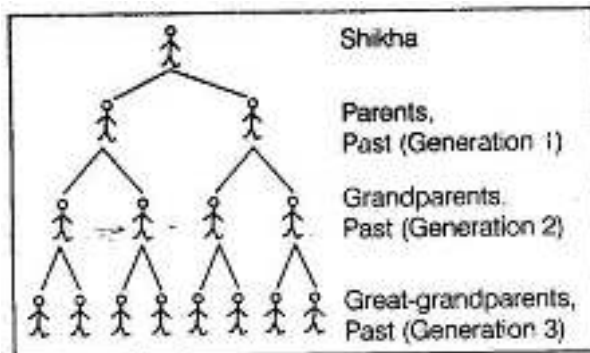

**Solution.**

(a) On the basis of given diagram, we can make a table that shows the number of ancestors in each of the 12 generations.

Generations	Ancestors
1st	2
2nd	$2^2$
3rd	$2^3$
⋮	⋮
12th	$2^{12}$

Hence, we can also make a graph that shows the relation between generation and ancestor.

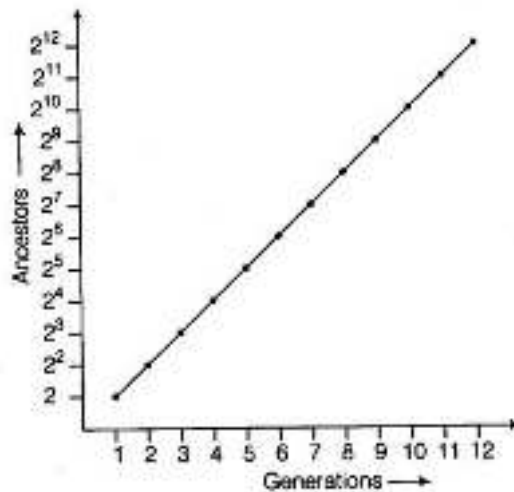

(b) On the basis of generation-ancestor graph, the number of ancestors in  $n$  generations will be  $2^n$ .

Question. 138 About 230 billion litres of water flows through a river each day, how many litres of water flows through that river in a week? How many litres of water flows through the river in an year? Write your answer in standard notation.

Solution.

Water flows through a river in each day = 230000000000 or 230 billion

Water flows through the river in a week =  $7 \times 230000000000$  [ $\because$  1 week = 7 days]  
 $= 1610000000000$   
 $= 1610$  billion  
 $= 1.61 \times 10^{12}$  L

Water flows through the river in an year =  $230000000000 \times 365$  [ $\because$  1 yr = 365 days]  
 $= 83950000000000$   
 $= 8.395 \times 10^{13}$  L

Question. 139 A half-life is the amount of time that it takes for a radioactive substance to decay one-half of its original quantity.

Suppose radioactive decay causes 300 grams of a substance to decrease  $300 \times 2^{-3}$  grams after 3 half-lives. Evaluate  $300 \times 2^{-3}$  to determine how many grams of the substance is left. Explain why the expression  $300 \times 2^{-n}$  can be used to find the amount of the substance that remains after  $n$  half-lives.

Solution.

Since, 300 g of a substance is decrease to  $300 \times 2^{-3}$  g after 3 half-lives.

So, we have to evaluate  $300 \times 2^{-3} = \frac{300}{8} = 37.5$  g [ $\because 2^3 = 8$ ]

Question. 140 Consider a quantity of a radioactive substance. The fraction of this quantity that remains after  $t$  half-lives can be found by using the expression  $3^{-t}$ .

(a) What fraction of the substance remains after 7 half-lives?

(b) After how many half-lives will the fraction be  $1/243$  of the original?

Solution.

(a) Since,  $3^{-t}$  expression is used for finding the fraction of the quantity that remains after  $t$  half-lives.

Hence, the fraction of substance remains after 7 half-lives will be equal to  $3^{-7}$ , i.e.  $\frac{1}{3^7}$

(b) Given,  $t$  half-lives =  $3^{-t}$

$$\text{So, } \frac{1}{243} = 3^{-t}$$

$$\Rightarrow \frac{1}{3^5} = \frac{1}{3^t} \quad \left[ \because 3 \times 3 \times 3 \times 3 \times 3 = 3^5 \text{ and } a^{-m} = \frac{1}{a^m} \right]$$

On comparing both sides, we get  $t = 5$  half-lives.

**Question. 141** One fermi is equal to  $10^{-15}$  metre. The radius of a proton is 1.3 fermi. Write the radius of a proton (in metres) in standard form.

**Solution.** The radius of a proton is 1.3 fermi.

One fermi is equal to  $10^{-15}$  m.

So, the radius of the proton is  $1.3 \times 10^{-15}$  m.

Hence, standard form of radius of the proton is  $1.3 \times 10^{-15}$  m.

**Question. 142** The paper clip below has the indicated length. What is the length in Standard form.

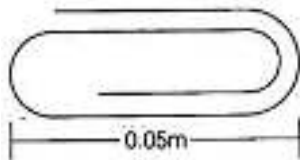

**Solution.**

Length of the paper clip = 0.05 m

In standard form,  $0.05 \text{ m} = 0.5 \times 10^{-1} = 5.0 \times 10^{-2} \text{ m}$

Hence, the length of the paper clip in standard form is  $5.0 \times 10^{-2} \text{ m}$

**Question. 143** Use the properties of exponents to verify that each statement is true.

(a)  $\frac{1}{4} (2^n) = 2^{n-2}$

(b)  $4^{n-1} = \frac{1}{4} (4)^n$

(c)  $25(5^{n-2}) = 5^n$

**Solution.**

(a)  $\frac{1}{4} (2^n) = 2^{n-2}$

$$\text{RHS} = 2^{n-2} = 2^n \div 2^2$$

$$[\because a^m \div a^n = (a)^{m-n}]$$

$$= \frac{2^n}{4} = \text{LHS}$$

(b)  $4^{n-1} = \frac{1}{4} (4)^n$

$$\text{LHS} = 4^{n-1} = 4^n \div 4^1$$

$$[\because a^m \div a^n = (a)^{m-n}]$$

$$= \frac{4^n}{4} = \text{RHS}$$

(c)  $25(5^{n-2}) = 5^n$

$$\text{LHS} = 25 (5^{n-2}) = 5^2 (5^n \div 5^2)$$

$$= 5^2 \times 5^n \times \frac{1}{5^2} = 5^n = \text{RHS}$$

**Question. 144** Fill in the blanks.

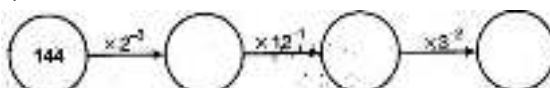



Solution.

$$144 \times 2^{-3} = 144 \times \frac{1}{8} = 18$$

$$18 \times 12^{-1} = 18 \times \frac{1}{12} = \frac{3}{2}$$

$$\frac{3}{2} \times 3^{-2} = \frac{3}{2} \times \frac{1}{3^2} = \frac{1}{2 \times 3} = \frac{1}{6}$$

Question. 145 There are 86400 sec in a day. How many days long is a second? Express your answer in scientific notation.

Solution. Total seconds in a day = 86400

So, a second is long as  $1/86400 = 0.000011574$

Scientific notation of  $0.000011574 = 1.1574 \times 10^{-5}$  days

Question. 146 The given table shows the crop production of a state in the year 2008 and 2009. Observe the table given below and answer the given questions.

Crop	2008 Harvest (Hectare)	Increase/Decrease (Hectare) in 2009
Bajra	$1.4 \times 10^3$	-100
Jowar	$1.7 \times 10^6$	-440000
Rice	$3.7 \times 10^3$	-100
Wheat	$5.1 \times 10^5$	+ 190000

(a) For which crop(s) did the production decrease?

(b) Write the production of all the crops in 2009 in their standard form.

(c) Assuming the same decrease in rice production each year as in 2009, how many acres will be harvested in 2015? Write in standard form.

Solution.

(a) On the basis of given table, bajra, jowar and rice crops's production decreased.

(b) The production of all crop in 2009

$$\text{Bajra} = 1.4 \times 10^3 - 0.1 \times 10^3 = 1.3 \times 10^3$$

$$\begin{aligned} \text{Jowar} &= 1.7 \times 10^6 - 44 \times 10^4 \\ &= 1.7 \times 10^6 - 0.44 \times 10^6 = 1.26 \times 10^6 \end{aligned}$$

$$\text{Rice} = 3.7 \times 10^3 - 0.1 \times 10^3 = 3.6 \times 10^3$$

$$\begin{aligned} \text{Wheat} &= 5.1 \times 10^5 + 19 \times 10^4 \\ &= 5.1 \times 10^5 + 1.9 \times 10^5 = 7 \times 10^5 \end{aligned}$$

(c) Incomplete information

Question. 147 Stretching Machine

Suppose you have a stretching machine which could stretch almost anything, e.g. If you put a 5 m stick into a (x 4) stretching machine (as shown below), you get a 20 m stick.

Now, if you put 10 cm carrot into a (x 4) machine, how long will it be when it comes out?

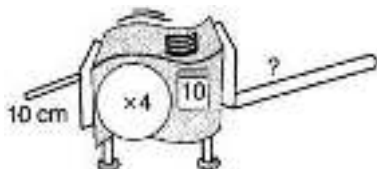

Solution.

According to the question, if we put a 5 m stick into a (x 4) stretching machine, then machine produces 20 m stick.

Similarly, if we put 10 cm carrot into a (x 4) stretching machine, then machine produce  $10 \times 4 = 40$  cm stick.

Question. 148 Two machines can be hooked together. When something is sent through this hook up, the output from the first machine becomes the input for the second.

- (a) Which two machines hooked together do the same work a ( $\times 10^2$ ) machine does? Is there more than one arrangement of two machines that will work?

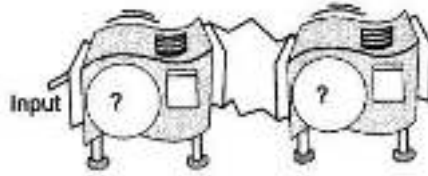

- (b) Which stretching machine does the same work as two ( $\times 2$ ) machines hooked together?

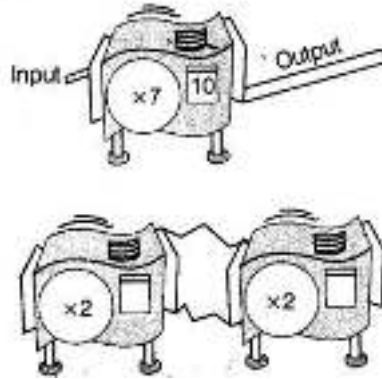

Solution.

- (a) For getting the same work a ( $\times 10^2$ ) machine does, we have to ( $\times 2^2$ ) and ( $\times 5^2$ ) machines hooked together.

$$\therefore \quad \times 10^2 = \times 100$$

$$\text{Similarly, } \times 2^2 \times 5^2 = \times 4 \times 25 = \times 100$$

- (b) If two machines ( $\times 2$ ) and ( $\times 2$ ) are hooked together to produce  $\times 4$ , then a ( $\times 4$ ) single machine produce the same work.

Question. 149 Repeater Machine

Similarly, repeater machine is a hypothetical machine which automatically enlarges items several times, e.g. Sending a piece of wire through a ( $\times 2^4$ ) machine is the same as putting it through a ( $\times 2$ ) machine four times.

So, if you send a 3 cm piece of wire through a ( $\times 2$ )<sup>4</sup> machine, its length becomes  $3 \times 2 \times 2 \times 2 \times 2 = 48$  cm. It can also be written that a base (2) machine is being applied 4 times.

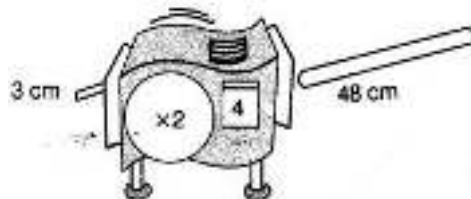

What will be the new length of a 4 cm strip inserted in the machine?

Solution.

According to the question, if we put a 3 cm piece of wire through a ( $\times 2^4$ ) machine, its length becomes  $3 \times 2 \times 2 \times 2 \times 2 = 48$  cm.

Similarly, 4 cm long strip becomes  $4 \times 2 \times 2 \times 2 \times 2 = 64$  cm.

Question. 150 For the following repeater machines, how many times the base machine is applied and how much the total stretch is?

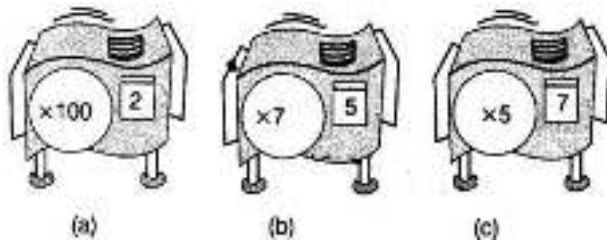

**Solution.**

In machine (a),  $(x 100^2) = 10000\text{stretch}$ . Since, it is two times the base machine.

In machine (b),  $(x 7^5) = 16807\text{ stretch}$ .

Since, it is fair times the base machine.

In machine (c),  $(x 5^7) = 78125\text{stretch}$ .

Since, it is 7 times the base machine.

**Question. 151 Find three repeater machines that will do the same work as a  $(x 64)$  machine.**

**Draw them, or describe them using exponents.'**

**Solution.**

We know that, the possible factors of 64 are 2, 4, 8. :

If  $2^6 = 64$ ,  $4^3 = 64$  and  $8^2 = 64$

Hence, three repeater machines that would work as a  $(x 64)$  will be  $(x 2^6)$ ,  $(x 4^3)$  and  $(x 8^2)$ .

The diagram of  $(x 2^6)$ ,  $(x 4^3)$  and  $(x 8^2)$  is given below.

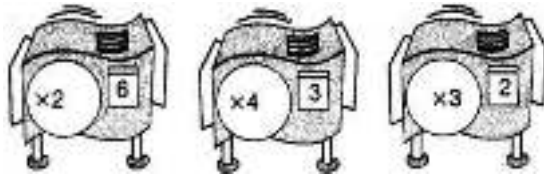

**Question. 152 What will the following machine do to a 2 cm long piece of chalk?**

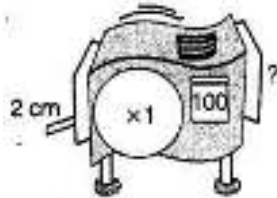

**Solution.**

The machine produce  $x 1^{100} = 1$

So, if we insert 2 cm long piece of chalk in that machine, the piece of chalk remains same.

**Question. 153 In a repeater machine with 0 as an exponent, the base machine is applied 0 times.**

**(a) What do these machines do to a piece of chalk?**

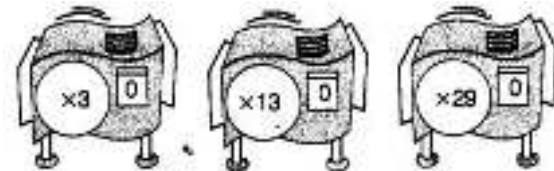

**(b) What do you think the value of  $6^0$  is?**

You have seen that a hookup of repeater machines with the same base can be replaced by a single repeater machine. Similarly, when you multiply exponential expressions with the same base, you can replace them with a single expression.

Asif Raza thought about how he could rewrite the expression  $220 \times 2^5$ .



Asif Raza's idea is one of the product laws of exponents, which can be expressed like this

Multiplying Expressions with the Same Base  $a^b \times a^c = a^{b+c}$

Actually, this law can be used with more than two expressions. As long as the bases are the same, to find the product you can add the exponents and use the same base.

Solution.

(a) Since,  $3^0 = 1$ ,  $13^0 = 1$ ,  $29^0 = 1$

Using law of exponents,  $a^0 = 1$  [∵ a is non-zero integer]

So, machine  $(\times 3^0)$ ,  $(\times 13^0)$  and  $(\times 29^0)$  produce nothing or not change the piece of chalk.

(b) Using the law of exponent,  $a^0 = 1$

[∵ a is non-zero integer]

Similarly,  $(\times 6^0)$  machine does not change the piece.

Question. 154 Shrinking Machine In a shrinking machine, a piece of stick is compressed to reduce its length. If 9 cm long sandwich is put into the shrinking machine below, how long will it be when it emerges?



Solution.

According to the question, in a shrinking machine, a piece of stick is compressed to reduce its length. If 9 cm long sandwich is put into the shrinking machine, then the length of sandwich will be  $9 \times \frac{1}{3} = 9 \div 3 = 3$  cm.

Question. 155 What happens when 1 cm worms are sent through these hook-ups?

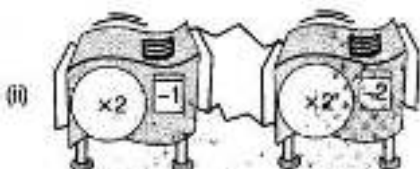
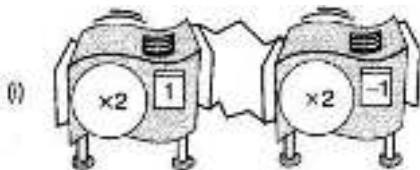

Solution.

(i) If 1 cm worms are sent through  $(\times 2^1)$  and  $(\times 2^{-1})$  machine, then the result comes with  $1 \times 2 \times \frac{1}{2} = 1$  cm.

(ii) If 1 cm worms are sent through  $(\times 2^{-1})$  and  $(\times 2)^{-2}$  hooked machine, the result comes with  $1 \times \frac{1}{2} \times \frac{1}{2 \times 2} = \frac{1}{2 \times 4} = \frac{1}{8}$  cm = 0.125 cm.

Question. 156 Sanchay put a 1 cm stick of gum through a  $(1 \times 3^{-2})$  machine. How long was the stick when it came out?

Solution.

If sanchay put a 1 cm stick of gum through a  $(1 \times 3^{-2})$  machine.

Negation (-) sign in power shrews it is a shrinking machine. So,  $1 \times \frac{1}{3^2} = 1 \times \frac{1}{9} = \frac{1}{9}$  cm

Hence,  $\frac{1}{9}$  cm stick came out.

Question. 157 Ajay had a 1 cm piece of gum. He put it through repeater machine given below and it came out  $\frac{1}{100000}$  cm long. What is the missing value?

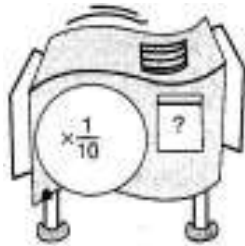

Solution.

Since, Ajay put a 1 cm piece of gum and came out  $\frac{1}{100000}$ .

So, it is shrinking machine.

Hence, it is a  $\left(\times \frac{1}{10}\right)^5$  type shrinking machine.

Thus, missing value is 5.

Question. 158 Find a single machine that will do the same job as the given hook-up.

(a) a  $(\times 2^3)$  machine followed by  $(\times 2^{-2})$  machine.

(b) a  $(\times 2^6)$  machine followed by  $\left(\times \left(\frac{1}{2}\right)^2\right)$  machine.

(c) a  $(\times 5^{99})$  machine followed by a  $(5^{-100})$  machine.

Maya multiplied  $(4^2 \times 3^2)$  by thinking about stretching machines.

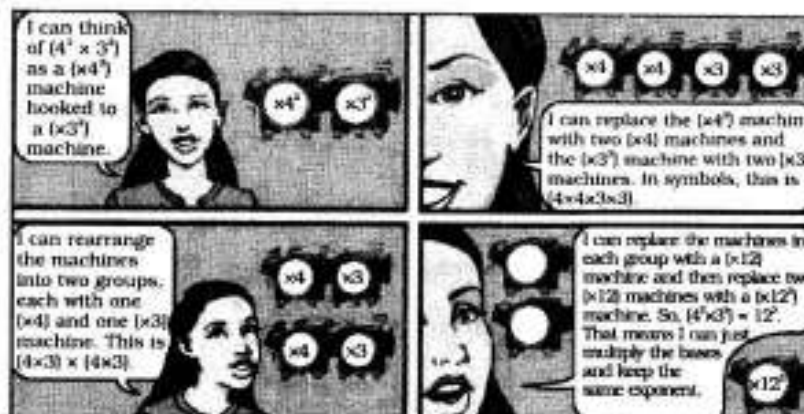

Use Maya's idea to multiply  $5^3 \times 2^3$ .

Maya's idea is another product law of exponents.

**Multiplying Expressions with the Same Exponents**

$$a^c \times b^c = (a \times b)^c$$

You can use this law with more than two expressions. If the exponents are the same, multiply the expressions by multiplying the bases and using the same exponent. e.g.  $2^8 \times 3^8 \times 7^8 = (2 \times 3 \times 7)^8 = 42^8$ .

Solution.

(a)  $(\times 2^3)$  machine followed by  $(\times 2^{-2})$  machine. So, it produces  $2 \times 2 \times 2 \times \frac{1}{2} \times \frac{1}{2} = 2^1$

Hence,  $(\times 2^1)$  single machine can do the same job as the given hook-up.

(b)  $(\times 2^4)$  machine followed by  $\left(\times \left(\frac{1}{2}\right)^2\right)$  machine.

So, it produces  $2 \times 2 \times 2 \times 2 \times \frac{1}{2} \times \frac{1}{2} = 4$

Hence,  $(\times 2^2)$  single machine can do the same job as the given hook-up.

(c)  $(\times 5^{99})$  machine followed by  $(\times 5^{-100})$  machine. So, it produces  $= 5^{99} \times \frac{1}{5^{100}} = \frac{1}{5}$

Hence,  $\left(\times \frac{1}{5}\right)$  machine can do the same job as the given hook-up.

Question. 159 Find a single repeater machine that will do the same work as each hook-up.

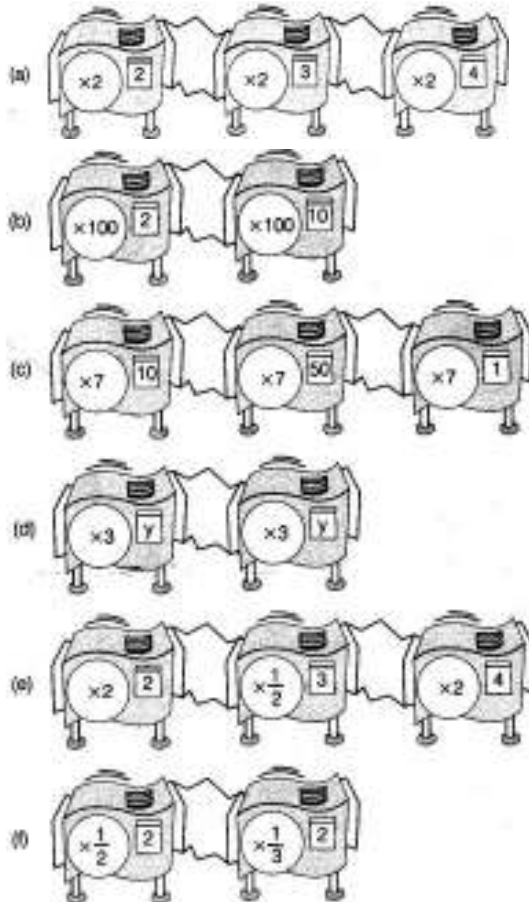

Solution.

Using law of exponents,  $(a^m \times a^n = a^{m+n})$  [ $\because a$  is non-zero integer]

(a) Repeater machine can do the work is equal to  $2^2 \times 2^3 \times 2^4 = 2^9$

So,  $(\times 2^9)$  single machine can do the same work.

(b) Repeater machine can do the work is equal to  $100^2 \times 100^{10}$ .

So,  $(\times 100^{12})$  single machine can do the same work.

(c) Repeater machine can do the work is equal to  $7^{10} \times 7^{50} \times 7^1 = 7^{61}$

So,  $(\times 7^{61})$  single machine can do the same work.

(d) Repeater machine can do the work is equal to  $3^7 \times 3^7 = 3^{14}$ .

So  $(\times 3^{14})$  single machine can do the same work.

(e) Repeater machine can do the work is equal  $2^2 \times \left(\frac{1}{2}\right)^3 \times 2^4 = 2^6 \times \frac{1}{2^3} = 2^3$

$$\left[ \because \frac{a^m}{a^n} = a^{m-n} \right]$$

So,  $(\times 2^3)$  single machine can do the same work.

(f) Repeater machine can do the work is equal to  $\left(\frac{1}{2}\right)^2 \times \left(\frac{1}{3}\right)^2$

$$= \frac{1}{2} \times \frac{1}{2} \times \frac{1}{3} \times \frac{1}{3} = \frac{1}{2 \times 3 \times 2 \times 3} = \frac{1}{(6)^2}$$

So,  $\left(\times \left(\frac{1}{6}\right)^2\right)$  single machine can do the same work. g47

Question. 160 For each hook-up, determine whether there is a single repeater machine that will do the same work. If so, describe or draw it.

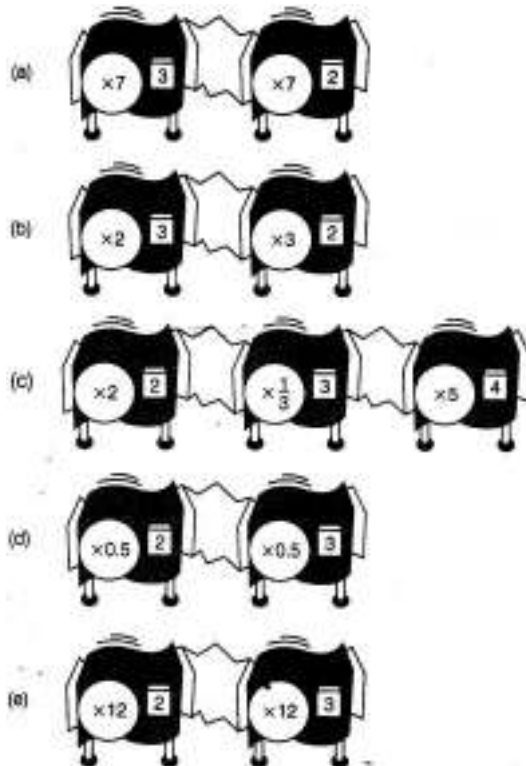

Solution.

Using law of exponents,  $a^m \times a^n = (a)^{m+n}$

[ $\because a$  is non-zero integer]

(a) Hook-up machine can do the work =  $7^3 \times 7^2 = 7^5$

So, ( $\times 7^5$ ) single machine can do the same work.

Diagram of single  $\times 7^5$  machine.



(b) Hook-up machine can do the work =  $2^3 \times 3^2 = 8 \times 9 = 72$

So, it is not possible for a single machine to do the same work.

Since, ( $\times 8^2$ ) = 64 and ( $\times 9^2$ ) = 81

(c) Hook-up machine can do the work =  $2^2 \times \left(\frac{1}{3}\right)^3 \times 5^4 = 4 \times \frac{1}{27} \times 625 = \frac{2500}{27} = 92.59$

So, it is not possible for a single machine to do the same work.

(d) Hook-up machine's work =  $(0.5)^2 \times (0.5)^3 = (0.5)^5$

[ $\because a^m \times a^n = a^{m+n}$ ]

So ( $\times (0.5)^5$ ) machine can for the same work.

Diagram of single  $\times (0.5)^5$  machine.

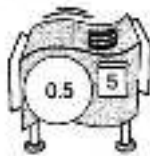

(e) Hook-up machine can do the work =  $12^2 \times 12^3 = 12^5$

[ $\because a^m \times a^n = (a)^{m+n}$ ]

So, ( $\times 12^5$ ) machine can do the same work.

Diagram of  $\times 12^5$  single machine.

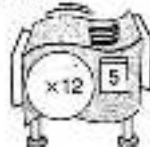

**Question. 161** Shikha has an order from a golf course designer to put palm trees through a ( $\times 2^3$ ) machine and then through a ( $\times 3^3$ ) machine. She thinks that she can do the job with a single repeater machine. What single repeater machine she should use?

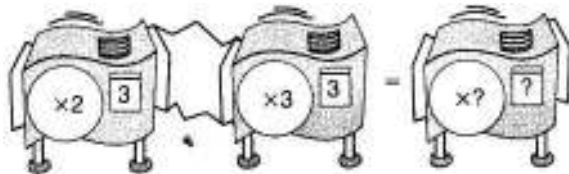

**Solution.**

Sol. The work done by hook-up machine is equal to  $2 \times 2 \times 2 \times 3 \times 3 \times 3 = 216 = 6^3$  So, she should use ( $\times 6^3$ ) single machine for the purpose.

**Question. 162** Neha needs to stretch some sticks to  $25^2$  times of their original lengths, but her ( $\times 25$ ) machine is broken. Find a hook-up of two repeater machines that will do the same work as a ( $\times 25^2$ ) machine. To get started, think about the hook-up you could use to replace the ( $\times 25$ ) machine.



**Solution.**

Work done by single machine ( $\times 25^2$ ) =  $25 \times 25 = 625$  or  $5 \times 5 \times 5 \times 5$  or  $52 \times 52$

Hence, ( $\times 5^2$ ) and ( $\times 5^2$ ) hook-up machine can replace the ( $\times 25$ ) machine.

**Question.163** Supply the missing information for each diagram.



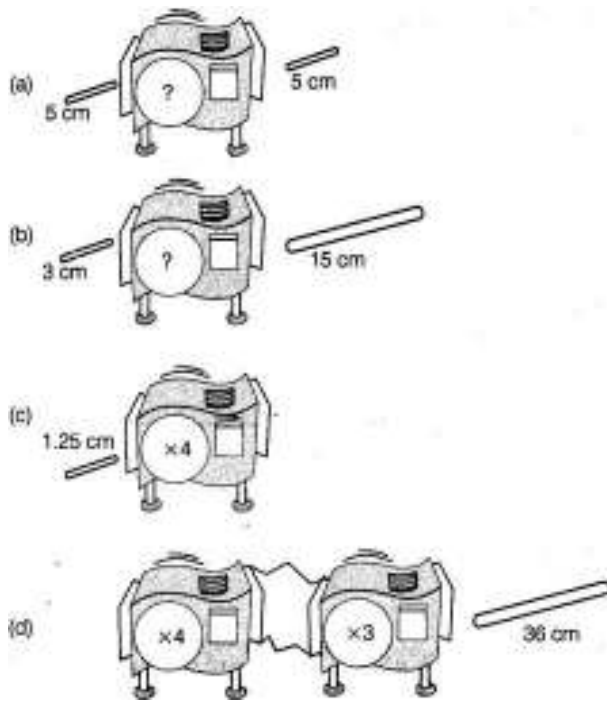

**solution.**

(a) If 5 cm long piece is inserted in single machine, then it produce same 5 cm long piece.

So, it is (x 1) repeated machine.

$$\therefore \quad ? = 1$$

(b) If 5 cm long piece inserted in single machine, then it produce 15 cm long piece.

So, it is (x 5) repeated machine.

$$\therefore \quad ? = 5$$

(c) If 1.25 cm long piece inserted in (x 4) repeated machine, then it will produce  $1.25 \times 4 = 10$  cm long piece.

$$\therefore \quad ? = 10 \text{ cm}$$

(d) If  $x$  cm long piece is inserted in (x 4) and (x 3) hooked machine, then it will produce 36 cm long piece.

$$\text{So,} \quad x \times 4 \times 3 = 36 \Rightarrow x = 3 \text{ cm}$$

**Question. 164** If possible, find a hook-up of prime base number machine that will do the same work as the given stretching machine. Do not use (x 1) machines.

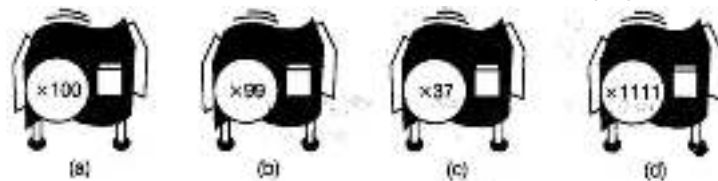

**solution.**

(a) Single machine work = 100

Hook-up machine of prime base number that do the same work down by x 100

$$= 2^2 \times 5^2$$

$$= 4 \times 25$$

$$= 100$$

(b)  $x 99 = 3^2 \times 11$  hook-up machine.

(c)  $x 37$  machine cannot do the same work.

(d)  $x 1111 = 101 \times 11$  hook-up machine.

**Question. 165** Find two repeater machines that will do the same work as a (x 81) machine.

**Solution.** Two repeater machines that do the same work as (x 81) are (x 3<sup>4</sup>) and (x 9<sup>2</sup>).

Since, factor of 81 are 3 and 9.

**Question. 166**

Find a repeater machine that will do the same work as a  $\left(\times \frac{1}{8}\right)$

machine.

Solution.

machine.

Since,  $\frac{1}{8}$  are  $\frac{1}{2}, \frac{1}{2}, \frac{1}{2}$

So,  $\frac{1}{8} = \frac{1}{2} \times \frac{1}{2} \times \frac{1}{2} = \left(\frac{1}{2}\right)^3$

Hence,  $\left(\times \frac{1}{2^3}\right)$  repeater machine can do the same work as a  $\left(\times \frac{1}{8}\right)$  machine.

Question. 167 Find three machines that can be replaced with hook-up of (x 5) machines.

Solution.

Since,  $5^2 = 25$ ,  $5^3 = 125$ ,  $5^4 = 625$

Hence,  $(\times 5^2)$ ,  $(\times 5^3)$  and  $(\times 5^4)$  machine can replace  $(\times 5)$  hook-up machine.

Question. 168 The left column of the chart lists is the length of input pieces of ribbon.

Stretching machines are listed across the top.

The other entries are the outputs for sending the input ribbon from that row through the machine from that column. Copy and complete the chart.

Input length	Machine			
	$\times 2$			
	1	5		
3				15
	14		7	

Solution.

In the given table, the left column of chart list is the length of input piece of ribbon. Thus, the outputs for sending the input ribbon are given in the following table.

Input length	Machine		
	$\times 2$	$\times 10$	$\times 5$
5	1	5	2.5
3	6	30	15
7	14	70	35

Question. 169 The left column of the chart lists is the length of input chains of gold.

Repeater machines are listed across the top. The other entries are the outputs you get when you send the input chain from that row through the repeater machine from that column.

Copy and complete the chart.

Input length	Repeater machine		
	$\times 2^3$		
	40		125
2		162	

Solution.

In the given table, the left column of the chart lists is the length of input chains of gold. Thus, the output we get when we send the input chain from the row through the repeater machine are detailed in the following table.

Input length	×3	×12	×9
13.3	40	160	125
2	6	24	18
13.5	141	162	121

Question.170 Long back in ancient times, a farmer saved the life of a king's daughter. The king decided to reward the farmer with whatever he wished. The farmer, who was a chess champion, made an unusual request

"I would like you to place 1 rupee on the first square of my chessboard. 2 rupees on the second square, 4 on the third square, 8 on the fourth square and so on, until you have covered all 64 squares. Each square should have twice as many rupees as the previous square." The king thought this to be too less and asked the farmer to think of some , better reward, but the farmer didn't agree.

How much money has the farmer earned?

[Hint The following table may help you. What is the first square on which the king will place atleast Rs. 10 lakh?]

Position of square on chessboard	Amount (in ₹)
1st square	1
2nd square	2
3rd square	4

Solution.

Given, a 8 × 8 grid.

Now, find the sum of each row,

$$\text{e.g. 1st row} = 2^0 + 2^1 + 2^2 + 2^3 + 2^4 + 2^5 + 2^6 + 2^7 = 255$$

$$\text{2nd row} = 2^8 + 2^9 + 2^{10} + 2^{11} + 2^{12} + 2^{13} + 2^{14} + 2^{15}$$

$$= 2^8 (2^0 + 2^1 + 2^2 + 2^3 + 2^4 + 2^5 + 2^6 + 2^7)$$

$$= 2^8 \times 255 = 255 \times 256 = 65280$$

$$\text{3rd row} = 2^{16} \times 255 = 16711680$$

$$[\because 2^8 = 256 \text{ and } 2^{16} = 2^8 \times 2^8 = 256 \times 256 \text{ and so on}]$$

Question. 171 The diameter of the Sun is  $1.4 \times 10^9$  m and the diameter of the Earth is  $1.2756 \times 10^7$  m. Compare their diameters by division.

Solution.

Diameter of the Sun =  $1.4 \times 10^9$  m

Diameter of the Earth =  $1.2756 \times 10^7$  m

For comparison, we have to change both diameter in same powers of 10 i.e.

$$1.2756 \times 10^7 = 0.012756 \times 10^9$$

Hence, if we divide diameter of Sun by diameter of Earth, we get

$$\frac{1.4 \times 10^9}{0.012756 \times 10^9} = 110$$

So, diameter of Sun is 110 times the diameter of Earth.

Question. 172 Mass of Mars is  $6.42 \times 10^{29}$  kg and mass of the Sun is  $1.99 \times 10^{30}$  kg. What is the total mass?

Solution.

Mass of Mars =  $6.42 \times 10^{29}$  kg

Mass of the Sun =  $1.99 \times 10^{30}$  kg

Total mass of Mars and Sun together =  $6.42 \times 10^{29} + 1.99 \times 10^{30}$

$$= 6.42 \times 10^{29} + 19.9 \times 10^{29} = 26.32 \times 10^{29} \text{ kg}$$

**Question. 173** The distance between the Sun and the Earth is  $1.496 \times 10^8$  km and : distance between the Earth and the Moon is  $3.84 \times 10^8$  m. During solar eclipse, the Moon comes in between the Earth and the Sun. What is the distance between the Moon and the Sun at that particular time?

**Solution.**

The distance between the Sun and the Earth is  $1.496 \times 10^8$  km

$$= 1.496 \times 10^8 \times 10^3 \text{ m} = 1496 \times 10^8 \text{ m}$$

The distance between the Earth and the Moon is  $3.84 \times 10^8$  m.

$$\text{The distance between the Moon and the Sun at particular time (solar eclipse)} = (1496 \times 10^8 - 3.84 \times 10^8) \text{ m} = 1492.16 \times 10^8 \text{ m}$$

**Question. 174** A particular star is at a distance of about  $8.1 \times 10^{13}$  km from the Earth. Assuming that light travels at  $3 \times 10^8$  m per second, find how long does light takes from that star to reach the Earth?

**Solution.**

$$\text{The distance between star and Earth} = 8.1 \times 10^{13} \text{ km} = 8.1 \times 10^{13} \times 10^3 \text{ m}$$

$$[\because 1 \text{ km} = 1000 \text{ m}]$$

Since, light travels at  $3 \times 10^8$  m per second.

So, time taken by light to reach the Earth

$$= \frac{8.1 \times 10^{13} \times 10^3}{3 \times 10^8} = \frac{8.1 \times 10^{16}}{3 \times 10^8} = \frac{8.1}{3} \times 10^8 = 2.7 \times 10^8 \text{ s}$$

**Question. 175** By what number should  $(-5)^{-1}$  be divided so that the quotient may be equal to  $(-5)^{-1}$ ?

**Solution.**

Let  $x$  be the number divide  $(-5)^{-1}$  to get  $(-5)^{-1}$  as a quotient.

$$\text{So, } (-5)^{-1} \div x = (-5)^{-1}$$

$$\Rightarrow \frac{1}{-5} \times \frac{1}{x} = \frac{1}{-5} \quad \left[ \because a^{-m} = \frac{1}{a^m} \right]$$

$$\Rightarrow \frac{1}{x} = \frac{1}{-5} \times \frac{-5}{-5} \Rightarrow \frac{1}{x} = \frac{1}{-5} \times \frac{-5}{1}$$

$$\Rightarrow x = 3$$

**Question. 176** By what number should  $(-8)^{-3}$  .be multiplied so that the product may be equal to  $(-6)^{-3}$ ?

**Solution.**

Let  $x$  be the number multiplied with  $(-8)^{-3}$  to get the product equal to  $(-6)^{-3}$ .

$$\Rightarrow x \times (-8)^{-3} = (-6)^{-3}$$

$$\Rightarrow x = \frac{(-6)^{-3}}{(-8)^{-3}} = \frac{(-6)^3}{(-8)^3} = \frac{512}{216} = \frac{64}{27}$$

**Question. 177** Find  $x$ .

$$(i) \left(-\frac{1}{7}\right)^5 + \left(-\frac{1}{7}\right)^{-7} = (-7)^x$$

Using law of exponents,  $a^m + a^n = (a)^{m+n}$

[ $\because a$  is non-zero integer]

$$\text{Then, } \left(-\frac{1}{7}\right)^{-5+7} = (-7)^x$$

$$\Rightarrow \left(-\frac{1}{7}\right)^2 = (-7)^x$$

$$\Rightarrow (-7)^{-2} = (-7)^x$$

On comparing powers of  $(-7)$ , we get  $x = -2$

$$(ii) \text{ We have, } \left(\frac{2}{5}\right)^{2x+8} \times \left(\frac{2}{5}\right)^3 = \left(\frac{2}{5}\right)^{x+2}$$

Using law of exponents,  $a^m \times a^n = (a)^{m+n}$

[ $\because a$  is non-zero integer]

$$\text{Then, } \left(\frac{2}{5}\right)^{2x+8+3} = \left(\frac{2}{5}\right)^{x+2}$$

On comparing powers of  $\left(\frac{2}{5}\right)$ , we get

$$2x + 6 + 3 = x + 2$$

$$\Rightarrow 2x + 9 = x + 2$$

$$\Rightarrow x = -7$$

Solution.

$$\Rightarrow 2^x (1+1+1) = 192$$

$$\Rightarrow 3 \times (2^x) = 192$$

$$\Rightarrow 2^x = \frac{192}{3} = 64$$

$$\Rightarrow 2^x = 2 \times 2 \times 2 \times 2 \times 2 \times 2$$

$$\Rightarrow 2^x = 2^6$$

On comparing the powers of 2, we get  $x = 6$

$$(iv) \text{ We have, } \left(-\frac{6}{7}\right)^{x-7} = 1$$

Using law of exponents,  $a^0 = 1$

[ $\because a$  is non-zero integer]

$$\text{Then, } \left(-\frac{6}{7}\right)^{x-7} = 1$$

It is possible only, if  $x = 7$ .

$$\text{So, } \left(-\frac{6}{7}\right)^{7-7} = 1$$

$$\Rightarrow \left(-\frac{6}{7}\right)^0 = 1$$

Hence,  $x = 7$

[ $\because a^0 = 1$ ]

$$(v) \text{ We have, } 2^{3x} = 8^{2x+1}$$

$$\Rightarrow 2^{3x} = (2^3)^{2x+1}$$

$$\Rightarrow 2^{3x} = 2^{6x+3}$$

[ $\because (a^m)^n = (a)^{m \times n}$ ]

On comparing the powers of 2, we get

$$3x = 6x + 3 \Rightarrow x = -1$$

$$(vi) 5^x + 5^{x-1} = 750$$

$$\Rightarrow 5^x + \frac{5^x}{5} = 750$$

$$\left[ \because a^{-m} = \frac{1}{a^m} \right]$$

$$\Rightarrow 5^x \left( 1 + \frac{1}{5} \right) = 750$$

$$\Rightarrow 5^x \left( \frac{6}{5} \right) = 750$$

$$\Rightarrow 5^x = 750 \times \frac{5}{6}$$

$$\Rightarrow 5^x = 125 \times 5$$

$$\Rightarrow 5^x = 625$$

$$\Rightarrow 5^x = 5^4$$

On comparing the powers of 5, we get

$$x = 4$$

$$(i) a^b + b^a$$

$$(ii) a^b - b^a$$

$$(iii) a^b \times b^a$$

$$(iv) a^b \div b^a$$

Question. 178 If  $a = -1$ ,  $b = 2$ , then find the value of the following,

$$(i) a^b + b^a \quad (ii) a^b - b^a$$

$$(iii) a^b \times b^a \quad (iv) a^b \div b^a$$

Solution.

$$(i) \text{ Given, } a^b + b^a$$

$$\text{If } a = -1 \text{ and } b = 2, \text{ then } (-1)^2 + (2)^{-1} = 1 + \frac{1}{2}$$

$$\left[ \because a^{-m} = \frac{1}{a^m} \right]$$

$$= \frac{2+1}{2} = \frac{3}{2}$$

$$(ii) \text{ Given, } a^b - b^a$$

$$\text{If } a = -1 \text{ and } b = 2, \text{ then } (-1)^2 - (2)^{-1} = 1 - \frac{1}{2}$$

$$\left[ \because a^{-m} = \frac{1}{a^m} \right]$$

$$= \frac{2-1}{2} = \frac{1}{2}$$

$$(iii) \text{ Given, } a^b \times b^a$$

$$\text{If } a = -1, b = 2, \text{ then } (-1)^2 \times (2)^{-1} = 1 \times \frac{1}{2} = \frac{1}{2}$$

$$\left[ \because a^{-m} = \frac{1}{a^m} \right]$$

$$(iv) \text{ Given, } a^b \div b^a$$

$$\text{If } a = -1 \text{ and } b = 2, \text{ then } (-1)^2 \div (2)^{-1} = 1 \div \frac{1}{2} = 1 \times 2 = 2$$

$$\left[ \because a^{-m} = \frac{1}{a^m} \right]$$

Question.179 Express each of the following in exponential form.

$$(i) \frac{-1296}{14641}$$

$$(ii) \frac{-125}{343}$$

$$(iii) \frac{400}{3969}$$

$$(iv) \frac{-625}{10000}$$

Solution.

$$(i) \text{ Given, } \frac{-1296}{14641}$$

$$\text{Since, } (6) \times (6) \times (6) \times (6) = 1296 = (6)^4 \text{ and } 11 \times 11 \times 11 \times 11 = 14641 = (11)^4$$

$$\text{Exponential form of } \frac{-1296}{14641} = -\frac{(6)^4}{(11)^4} = -\left(\frac{6}{11}\right)^4$$

(ii) Given,  $\frac{-125}{343}$

Since,  $(-5) \times (-5) \times (-5) = -125 = (-5)^3$  and  $7 \times 7 \times 7 = 343 = (7)^3$

Exponential form of  $\frac{-125}{343} = \frac{(-5)^3}{(7)^3} = \left(\frac{-5}{7}\right)^3$

(iii) Given,  $\frac{400}{3969}$

Since,  $20 \times 20 = 400 = (20)^2$  and  $63 \times 63 = 3969 = (63)^2$

Exponential form of  $\frac{400}{3969} = \frac{(20)^2}{(63)^2} = \left(\frac{20}{63}\right)^2$

(iv) Given,  $\frac{-625}{10000}$

Since,  $5 \times 5 \times 5 \times 5 = 625 = (5)^4$  and  $10 \times 10 \times 10 \times 10 = 10000 = (10)^4$

Exponential form of  $\frac{-625}{10000} = \frac{-(5)^4}{(10)^4} = -\left(\frac{1}{2}\right)^4$

Question. 180 Simplify

(i)  $\left[\left(\frac{1}{2}\right)^2 - \left(\frac{1}{4}\right)^3\right]^{-1} \times 2^{-3}$

(ii)  $\left[\left(\frac{4}{3}\right)^{-2} - \left(\frac{3}{4}\right)^2\right]^{-(-2)}$

(iii)  $\left(\frac{4}{13}\right)^4 \times \left(\frac{13}{7}\right)^2 \times \left(\frac{7}{4}\right)^3$

(iv)  $\left(\frac{1}{5}\right)^{45} \times \left(\frac{1}{5}\right)^{-60} - \left(\frac{1}{5}\right)^{28} \times \left(\frac{1}{5}\right)^{-41}$

(v)  $\frac{(9)^3 \times 27 \times t^4}{(3)^{-2} \times (3)^4 \times t^2}$

(vi)  $\frac{(3^{-2})^2 \times (5^2)^{-3} \times (t^{-3})^2}{(3^{-2})^5 \times (5^3)^{-2} \times (t^{-4})^3}$

Solution.

(i) Given,  $\left[\left(\frac{1}{2}\right)^2 - \left(\frac{1}{4}\right)^3\right]^{-1} \times 2^{-3} = \left(\frac{1}{4} - \frac{1}{64}\right)^{-1} \times 2^{-3}$   
 $= \left(\frac{16-1}{64}\right)^{-1} \times 2^{-3}$   
 $= \left(\frac{15}{64}\right)^{-1} \times 2^{-3}$   
 $= \frac{64}{15} \times \frac{1}{8}$   
 $= \frac{8}{15}$

$$\left[\because a^{-m} = \frac{1}{a^m}\right]$$

$$(ii) \left[ \left( \frac{4}{3} \right)^{-2} - \left( \frac{3}{4} \right)^2 \right]^{-2} = \left[ \left( \frac{3}{4} \right)^2 - \left( \frac{3}{4} \right)^2 \right]^{-2} = [0]^{-2} = 0$$

$$(iii) \left( \frac{4}{13} \right)^4 \times \left( \frac{13}{7} \right)^2 \times \left( \frac{7}{4} \right)^3 = \frac{(4)^4}{(13)^4} \times \frac{(13)^2}{(7)^2} \times \frac{(7)^3}{(4)^3}$$

$$= (4)^4 \times (4)^{-3} \times (13)^2 \times (13)^{-4} \times (7)^3 \times (7)^{-2} \quad \left[ \because a^{-m} = \frac{1}{a^m} \right]$$

$$= (4)^{4-3} \times (13)^{2-4} \times (7)^{3-2} \quad [\because a^m \times a^n = a^{m+n}]$$

$$= (4)^1 \times (13)^{-2} \times (7)^1$$

$$= 4 \times \frac{1}{169} \times 7 \quad \left[ \because a^{-m} = \frac{1}{a^m} \right]$$

$$= \frac{28}{169}$$

$$(iv) \left( \frac{1}{5} \right)^{45} \times \left( \frac{1}{5} \right)^{-60} - \left( \frac{1}{5} \right)^{28} \times \left( \frac{1}{5} \right)^{-43} = \frac{1}{(5)^{45}} \times \frac{1}{(5)^{-60}} - \frac{1}{(5)^{28}} \times \frac{1}{(5)^{-43}}$$

$$= \frac{1}{(5)^{45-60}} - \frac{1}{(5)^{28-43}} \quad [\because a^m \times a^n = (a)^{m+n}]$$

$$= \frac{1}{(5)^{-15}} - \frac{1}{(5)^{-15}} = (5)^{15} - (5)^{15} \quad \left[ \because a^{-m} = \frac{1}{a^m} \right]$$

$$= 0$$

$$(v) \frac{(9)^3 \times 27 \times t^4}{(3)^{-2} \times (3)^4 \times t^2} = \frac{(3^2)^3 \times (3)^3 \times t^4}{(3)^{-2} \times (3)^4 \times t^2} \quad [\because 3 \times 3 = 3^2 = 9]$$

$$= \frac{(3)^6 \times (3)^3 \times t^4}{(3)^{-2} \times (3)^4 \times t^2} = (3)^6 \times (3)^3 \times (3)^2 \times (3)^{-4} \times t^4 \times t^{-2} \quad \left[ \because a^{-m} = \frac{1}{a^m} \right]$$

$$= (3)^{11-4} \times t^{4-2} = (3)^7 \times t^2 \quad [\because a^m \times a^n = (a)^{m+n}]$$

$$(vi) \frac{(3^{-2})^2 \times (5^2)^{-3} \times (t^{-3})^2}{(3^{-2})^3 \times (5^3)^{-2} \times (t^{-4})^3} = \frac{(3)^{-4} \times (5)^{-6} \times (t)^{-6}}{(3)^{-10} \times (5)^{-6} \times (t)^{-12}}$$

$$= (3)^{-4} \times (3)^{10} \times (5)^{-6} \times (5)^6 \times (t)^{-6} \times (t)^{12}$$

$$= (3)^{-4+10} \times (5)^{-6+6} \times (t)^{-6+12} \quad \left[ \because a^{-m} = \frac{1}{a^m} \right]$$

$$= (3)^6 \times 5^0 \times (t)^6 = (3t)^6 \quad [\because a^0 = 1]$$