

## Multiple Choice Questions

### Single Correct Answer Type

Q1. A ball is travelling with uniform translatory motion. This means that

- (a) it is at rest.
- (b) the path can be a straight line or circular and the ball travels with uniform
- (c) all parts of the ball have the same velocity (magnitude and direction) and the velocity is constant.
- (d) the centre of the ball moves with constant velocity and the ball spins about its centre uniformly.

**Sol:** (c) When a body moves in such a way that the linear distance covered by each particle of the body is same during the motion, then the motion is said to be translatory or translation motion.

Translatory motion can be, again of two types viz., curvilinear (shown in fig. (a)) or rectilinear (shown in fig. (b)), accordingly as the paths of every constituent particles are similarly curved or straight line paths. Here it is important that the body does not change its orientation. Here we can also define it further in uniform and non-uniform translatory motion. Here figure (b) is uniformly translatory motion.

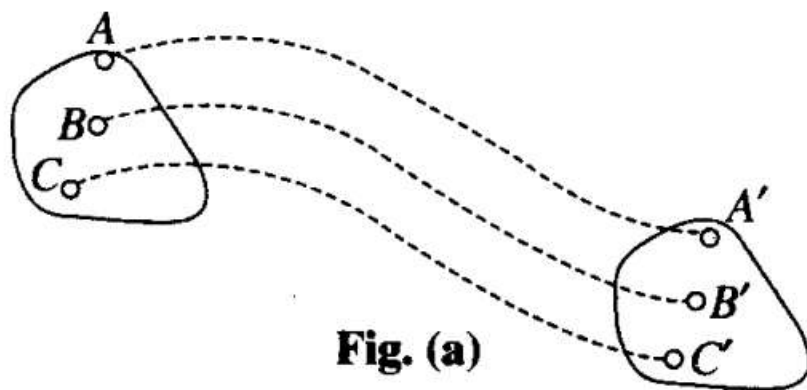

**Fig. (a)**

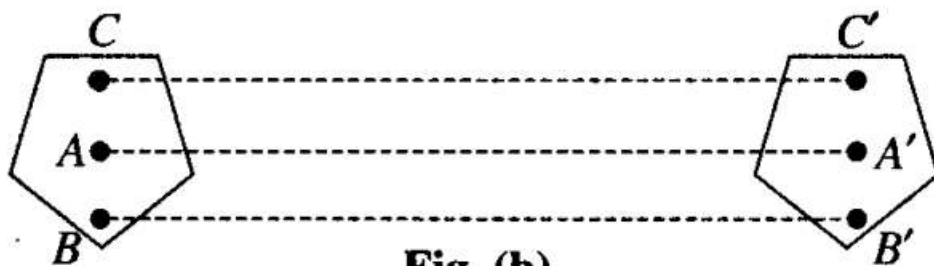

**Fig. (b)**

Q2. A metre scale is moving with uniform velocity. This implies

- (a) the force acting on the scale is zero, but a torque about the centre of mass can act on the scale.
- (b) the force acting on the scale is zero and the torque acting about centre of mass of the scale is also zero.

**(c) the total force acting on it need not be zero but the torque on it is zero.**

**(d) neither the force nor the torque need to be zero.**

**Sol:** (b)

Key concept: To solve these types of problem we have to apply Newton's second law of motion!

Newton's Second Law of Motion

According to this law: The rate of change of linear momentum of a body is directly proportional to the external force applied on the body and this change takes place always in the direction of the force applied.

**3. A cricket ball of mass 150 g has an initial velocity  $u = (3\hat{i} + 4\hat{j}) \text{ ms}^{-1}$  and a final velocity  $v = -(3\hat{i} + 4\hat{j}) \text{ ms}^{-1}$  after being hit. The change in momentum (final momentum – initial momentum) is (in  $\text{kg}\cdot\text{ms}^{-1}$ )**

**(a) zero**

**(b)  $-(0.45\hat{i} + 0.6\hat{j})$**

**(c)  $-(0.9\hat{j} + 1.2\hat{j})$**

**(d)  $-5(\hat{i} + \hat{j})$**

takes place always in the direction of the force applied.

We know that  $F = dp/dt$

According to the question that the meter scale is moving with uniform velocity, hence, change in momentum will be zero, i.e.  $dp = 0$

This implies momentum will remain same. So, Force =  $F = 0$ .

So, we can say that all parts of the meter scale is moving with uniform velocity because total force is zero and if there is any torque acting on the body this means that the body will be in rotational motion which means that the direction of velocity will be changing continuously. So, the torque acting about centre of

mass of the scale is also zero.

**Sol. (c)** According to the problem,  $u = (3\hat{i} + 4\hat{j})\text{m/s}$

and  $v = -(3\hat{i} + 4\hat{j})\text{m/s}$

Mass of the ball = 150 g = 0.15 kg

Change in momentum will be

$$\vec{\Delta p} = \vec{p}_f - \vec{p}_i$$

$$= m\vec{v} - m\vec{u}$$

$$= m(\vec{v} - \vec{u})$$

$$= (0.15)[-(3\hat{i} + 4\hat{j}) - (3\hat{i} + 4\hat{j})]$$

$$= (0.15)[-6\hat{i} - 8\hat{j}]$$

$$= -[0.15 \times 6\hat{i} + 0.15 \times 8\hat{j}]$$

$$= -[0.9\hat{i} + 1.20\hat{j}]$$

Hence,  $\vec{\Delta p} = -[0.9\hat{i} + 1.2\hat{j}]$

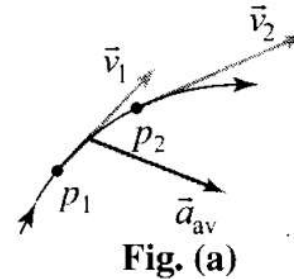

**Fig. (a)**

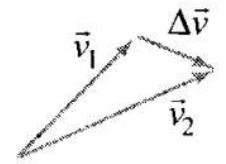

**Fig. (b)**

Important point: Change in velocity = final velocity – initial velocity

**4. In the previous problem (Q. 3), the magnitude of the momentum transferred during the hit is**

(a) zero

(b)  $0.75\text{ kg}\cdot\text{m s}^{-1}$

(c)  $1.5\text{ kg}\cdot\text{m s}^{-1}$

(d)  $14\text{ kg}\cdot\text{m s}^{-1}$

**Sol. (c)** By previous solution,  $\vec{\Delta p} = -(0.9\hat{i} + 1.2\hat{j})$

$$\text{Magnitude} = |\Delta p| = \sqrt{(0.9)^2 + (1.2)^2}$$

$$= \sqrt{0.81 + 1.44} = 1.5\text{ kg}\cdot\text{ms}^{-1}.$$

**Q5. Conservation of momentum in a collision between particles can be understood from**

(a) Conservation of energy

(b) Newton's first law only

(c) Newton's second law only

(d) Both Newton's second and third law

**Sol:** (d)

Key concept: If no external force acts on a system (called isolated) of constant mass, the total momentum

of the system remains constant with time.

According to this law for a system of particles  $\vec{F} = \frac{d\vec{p}}{dt}$

In the absence of external force  $\vec{F} = 0$ , then  $\vec{p} = \text{constant}$

i.e.,  $\vec{p} = \vec{p}_1 + \vec{p}_2 + \vec{p}_3 + \dots = \text{constant}$

or,  $m_1\vec{v}_1 + m_2\vec{v}_2 + m_3\vec{v}_3 + \dots = \text{constant}$

This equation shows that in absence of external force for a closed system the linear momentum of individual particles may change but their sum remains unchanged with time.

Conservation of linear momentum is equivalent to Newton's third law of motion.

For a system of two particles in absence of external force by law of conservation of linear momentum.

$$\vec{p}_1 + \vec{p}_2 = \text{constant.} \quad \therefore m_1\vec{v}_1 + m_2\vec{v}_2 = \text{constant}$$

Differentiating above with respect to time,

$$m_1 \frac{d\vec{v}_1}{dt} + m_2 \frac{d\vec{v}_2}{dt} = 0 \Rightarrow m_1\vec{a}_1 + m_2\vec{a}_2 = 0$$

$$\Rightarrow \vec{F}_1 + \vec{F}_2 = 0$$

$$\therefore \vec{F}_2 = -\vec{F}_1$$

i.e., for every action there is equal and opposite reaction which is Newton's third law of motion.

In case of collision between particles equal and opposite forces will act on individual particles by Newton's third law.

Hence total force on the system will be zero.

Important point: We should not confuse with system and individual particles. As total force on the system of both particles is zero but force acts on individual particles.

Law of conservation of linear momentum is independent of frame of reference though linear momentum depends on frame of reference.

**Q6. A hockey player is moving northward and suddenly turns westward with the same speed to avoid an opponent. The force that acts on the player is**

- (a) frictional force along westward (b) muscle force along southward (c) frictional force along south-west (d) muscle force along south-west

**Sol:** (c)

Key concept: According to Newton's second law of motion only external forces can change linear momentum of the system. The internal forces cannot change linear momentum of system under consideration. If we take hockey player as a system, the external force which can change the direction of motion of the player is the force must be friction between the ground and shoes of player. The muscle force is the internal force, this cannot change the linear momentum of the player. According to Newton's Second Law, The rate of change of linear momentum of a body is equal to the external force applied on the body or  $F = dp/dt$ . So, the external force must be in the direction of change in momentum.

As shown in the diagram,

Let  $OA = p_1$   
 = Initial momentum of player  
 northward

$AB = p_2 =$  Final momentum of player  
 towards west

Clearly  $OB = OA + AB$

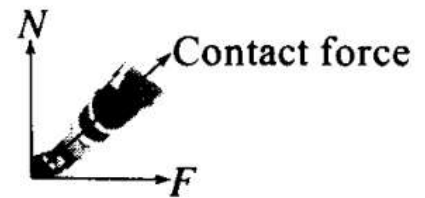
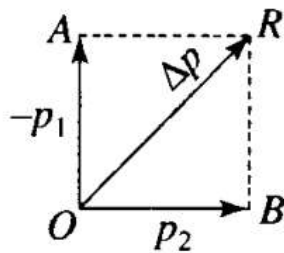
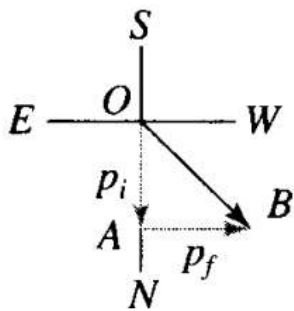
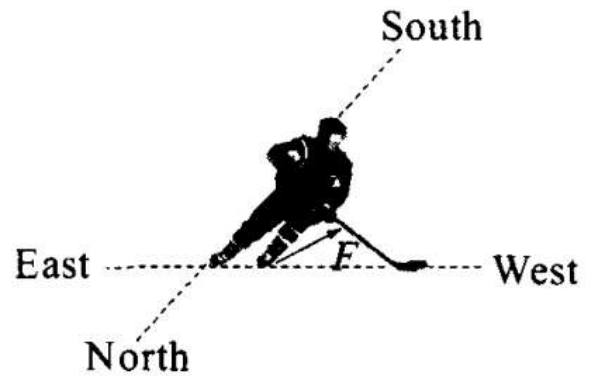

According to the problem, mass = 2 kg

Position of the particle is given here as a function of time,  $x(t) = pt + qt^2 + rt^3$  By differentiating this equation w.r.t. time we get velocity of the particle as a function of time.

$$v = dx/dt = p + 2qt + 3rt^2$$

If we again differentiate this equation w.r.t. time, we will get acceleration of the particle as a function of time.

$$a = dv/dt = 0 + 2q + 6rt$$

$$\text{At } t = 2 \text{ s; } a = 2q + 6x2r$$

$$= 2q + 12r$$

$$= 2 \times 4 + 12 \times 5$$

$$= 8 + 60 = 68 \text{ m/s}$$

$$\text{Force } = F = ma$$

$$= 2 \times 68 = 136 \text{ N}$$

$$\begin{aligned} \text{Change in momentum} &= p_2 - p_1 \\ &= AB - OA = AB + (-OA) \end{aligned}$$

= Clearly the change in momentum is OR will be along south-west, so direction of force will also be along south-west.

7. A body of mass 2 kg travels according to the law  $x(t) = pt + qt^2 + rt^3$ , where  $q = 4 \text{ ms}^{-2}$ ,  $p = 3 \text{ ms}^{-1}$  and  $r = 5 \text{ ms}^{-3}$ . The force acting on the body at  $t = 2 \text{ s}$  is

- (a) 136 N                      (b) 134 N                      (c) 158 N                      (d) 168 N

**Sol. (a)** First we have to calculate acceleration and then Newton's second law will be applied.

8. A body with mass 5 kg is acted upon by a force  $F = (-3\hat{i} + 4\hat{j})\text{N}$ . If its initial velocity at  $t = 0$  is  $v = (6\hat{i} - 12\hat{j})\text{ms}^{-1}$  the time at which it will just have a velocity along the y-axis is

- (a) never                      (b) 10 s                      (c) 2 s                      (d) 15 s

**Sol. (b)** According to the problem, mass  $m = 5 \text{ kg}$

Force which is acting upon the block  $\vec{F} = (-3\hat{i} + 4\hat{j})\text{N}$

Initial velocity at  $t = 0$ ,  $\vec{u} = (6\hat{i} - 12\hat{j})\text{m/s}$

$$\text{Retardation, } \vec{a} = \frac{\vec{F}}{m} = \left( -\frac{3\hat{i}}{5} + \frac{4\hat{j}}{5} \right) \text{m/s}^2$$

And when final velocity is along y-axis only, its x-component must be zero. We have to apply kinematic equations separately for x-component only. Then we get

$$v_x = u_x + a_x t$$

$$0 = 6\hat{i} - \frac{3\hat{i}}{5} t$$

$$t = \frac{5 \times 6}{3} = 10 \text{ s}$$

9. A car of mass  $m$  starts from rest and acquires a velocity along east,  $\vec{v} = v\hat{i}$  ( $v > 0$ ) in two seconds. Assuming the car moves with uniform acceleration, the force exerted on the car is

(a)  $\frac{mv}{2}$  eastward and is exerted by the car engine.

(b)  $\frac{mv}{2}$  eastward and is due to the friction on the tyres exerted by the road.

(c) more than  $\frac{mv}{2}$  eastward exerted due to the engine and overcomes the friction of the road.

(d)  $\frac{mv}{2}$  exerted by the engine.

Let us assume the eastward direction as x-axis.

A car is able to move towards due to friction acting between its tyres and the road.

The force of friction of the road on the tyre acts in the forward direction and is equal but in the opposite direction to the force of friction of the tyre on the road.

Mass of the car =  $m$

As car starts from rest, its initial velocity  $u = 0$  Velocity acquired along east =  $v\hat{i}$

Time interval (in which car acquired that velocity)  $t = 2$  s.

As acceleration is uniform, so by applying kinematic equation ( $v = u + at$ ), we get

$$v = u + at$$

$$\Rightarrow v\hat{i} = 0 + a \times 2$$

$$\Rightarrow a = \frac{v}{2}\hat{i}$$

$$\text{Force, } F = ma = \frac{mv}{2}\hat{i}$$

Hence, force acting on the car is  $\frac{mv}{2}$  towards east. As external force on the

system is only friction, hence the force  $\frac{mv}{2}$  is by friction. Hence, force by engine is internal force.

**More Than One Correct Answer Type**

Q10. The motion of a particle of mass  $m$  is given by  $x = 0$  for  $t < 0$  s,  $x(t) = A \sin 4\pi t$  for  $0 < t < (1/4)$  s ( $A > 0$ ), and  $x = 0$  for  $t > (1/4)$  s.

Which of the following statements is true?

- The force at  $t = (1/8)$  s on the particle is  $-16\pi^2 A m$ .
- The particle is acted upon by an impulse of magnitude  $4\pi A m$  at  $t = 0$  s and  $t = (1/4)$  s.
- The particle is not acted upon by any force.
- The particle is not acted upon by a constant force.
- There is no impulse acting on the particle.

**Sol:** (a, b, d) For different time intervals position of the particle is given. Hence, we have to find velocity and acceleration corresponding to the intervals.



Given,  $x = 0$  ; for  $t < 0$  s.

$$x(t) = A \sin 4\pi t; \text{ for } 0 < t < \frac{1}{4} \text{ s}$$

By differentiating this equation w.r.t. time, we get velocity of the particle as a function of time.

$$\text{For, } 0 < t < \frac{1}{4} \text{ s, } \quad v(t) = \frac{dx}{dt} = 4\pi A \cos 4\pi t$$

If we again differentiate this equation w.r.t. time, we will get acceleration of the particle as a function of time (at a particular time).

$$a(t) = \frac{dv(t)}{dt} = -16\pi^2 A \sin 4\pi t$$

$$\text{At } t = \frac{1}{8} \text{ s, } a(t) = -16\pi^2 A \sin 4\pi \times \frac{1}{8} = -16\pi^2 A$$

$$F = m[a(t)] = -16\pi^2 A \times m = -16\pi^2 mA$$

Hence option (a) is correct.

Impulse = Change in linear momentum

$$= F \times t = (-16\pi^2 Am) \times \frac{1}{4} = -4\pi^2 Am$$

The impulse (Change in linear momentum) at  $t = 0$  is same as  $t = \frac{1}{4}$  s.

Hence, option (b) is correct.

The impulse (Change in linear momentum) at  $t = 0$  is same as  $t = 1/4$  s. Hence, option (b) is correct.

We know that, force depends upon acceleration and which is not constant here. Hence, force is also not constant. Hence option (d) is also correct.

Important point: We have to keep in mind that the force is varying for different time intervals. Hence, we should apply differential formulae for each interval separately.

**Q11.** In figure the co-efficient of friction between the floor and the body B is 0.1. The co-efficient of friction between the bodies B and A is 0.2. A force F is applied as shown on B. The mass of A is  $m/2$  and of B is

m. Which of the following statements are true?

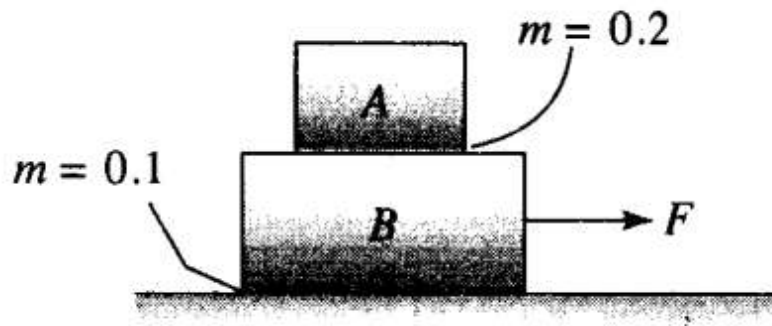

- (a) The bodies will move together if  $F = 0.25 \text{ mg}$ .
- (b) The body A will slip with respect to B if  $F = 0.5 \text{ mg}$ .
- (c) The bodies will move together if  $F = 0.5 \text{ mg}$ .
- (d) The bodies will be at rest if  $F = 0.1 \text{ mg}$ .
- (e) The maximum value of  $F$  for which the two bodies will move together is  $0.45 \text{ mg}$ .

**Sol:** (a, b, d, e)

Key concept: A force  $F$  is applied to the lower body, then following four situations are possible.

(i) When there is no friction

(a)  $B$  will move with acceleration  $(F/M)$  while  $A$  will remain at rest (relative to ground) as there is no pulling force on  $A$ .

$$a_B = \left( \frac{F}{M} \right) \text{ and } a_A = 0$$

(b) As relative to  $B$ ,  $A$  will move backwards with acceleration  $(F/M)$  and so will fall from it in time  $t$ .

$$\therefore t = \sqrt{\frac{2L}{a}} = \sqrt{\frac{2ML}{F}}$$



(ii) If friction is present between  $A$  and  $B$  only and  $F' < F_l$

(where  $F'$  = Pseudo force on body  $A$  and  $F_l$  = limiting friction between body  $A$  and  $B$ )

(a) Both the body will move together with common acceleration

$$a = \frac{F}{M + m}$$

(b) Pseudo force on the body  $A$ ,

$$F' = ma = \frac{mF}{m + M} \text{ and } F_l = \mu_s mg$$

$$(c) F' < F_l \Rightarrow \frac{mF}{m + M} < \mu_s mg$$

$$\Rightarrow F < \mu_s(m + M)g$$

So both bodies will move together with acceleration  $a_A = a_B$

$$= \frac{F}{m + M} \text{ if } F < \mu_s[m + M]g$$

- (iii) If friction is present between  $A$  and  $B$  only and  $F > F_1'$   
 (where  $F_1' = \mu_s mg =$  limiting friction between body  $A$  and  $B$ )  
 Both the body will move with different acceleration. Here force of kinetic friction  $\mu_k mg$  will oppose the motion of  $B$  which will cause the motion of  $A$ .

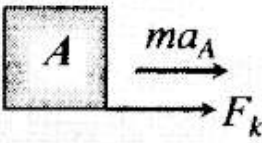
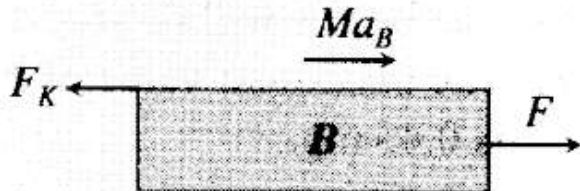
$ma_A = \mu_k mg$ $\text{i.e. } a_A = \mu_k g$	Free body diagram of $A$ 
$F - F_k = Ma_B$ $\text{i.e. } a_B = \frac{[F - \mu_k mg]}{M}$	Free body diagram of $B$ 

**Note :** As both the bodies are moving in the same direction,  
 Acceleration of body  $A$  relative to  $B$  will be

$$a = a_A - a_B = - \left[ \frac{F - \mu_k g(m + M)}{M} \right]$$

Negative sign implies that relative to  $B$ ,  $A$  will move backwards and will fall it after time  $t$ .

$$= \sqrt{\frac{2L}{a}} = \sqrt{\frac{2ML}{F - \mu_k g(m + M)}}$$

- (iv) If there is friction between  $B$  and floor and  $F > F_1''$ :  
 (where  $F_1'' = \mu_s(m + M)g =$  limiting friction between body  $B$  and surface)  
 The system will move only if  $F > F_1''$  then replacing  $F$  by  $F - F_1''$ .  
 The entire case (iii) will be valid.  
 However if  $F < F_1''$  the system will not move and friction between  $B$  and floor will be  $F$  while between  $A$  and  $B$  is zero.

To here first we have to find first frictional forces on each surface and accordingly we will decide maximum force. The friction force always have tendency to oppose the motion.

In the given diagram, let the frictional force between floor and block B is ( $f_1$ ) and frictional force between block B and A is ( $f_2$ ) will be as shown. '

Let A and B are moving together

$$a_{\text{common}} = \frac{F - f_1}{m_A + m_B} = \frac{F - f_1}{(m/2) + m} = \frac{2(F - f_1)}{3m}$$

Pseudo force on A = ( $m_A$ )  $\times$   $a_{\text{common}}$

$$= m_A \times \frac{2(F - f_1)}{3m} = \frac{m}{2} \times \frac{2(F - f_1)}{3m} = \frac{(F - f_1)}{3}$$

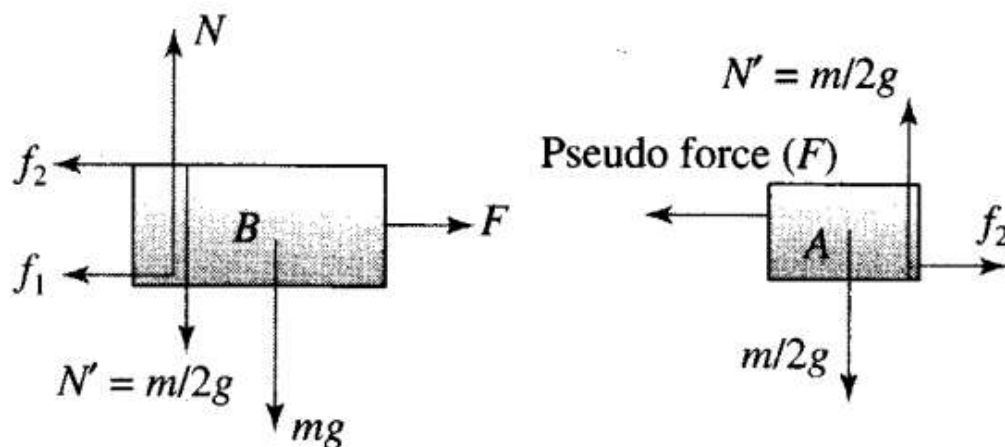

The force ( $F$ ) will be maximum when the blocks are moved together, then Pseudo force on A = Frictional force on A

$$\frac{F_{\text{max}} - f_1}{3} = \mu m_A g = 0.2 \times \frac{m}{2} \times g = 0.1 mg$$

$$\Rightarrow F_{\text{max}} = 0.3 mg + f_1$$

$$= 0.3 mg = (0.1) \frac{3}{3} mg = 0.45 mg$$

Similarly, we can find the minimum force required, so that both the blocks were moved together.

Hence, maximum force up to which bodies will move together is  $F_{\max} = 0.45$  mg

- (a) Hence, for  $F = 0.25$  mg  $< F_{\max}$  bodies will move together.  
 (b) For  $F = 0.5$  mg  $> F_{\max}$ , body  $A$  will slip with respect to  $B$ .  
 (c) For  $F = 0.5$  mg  $> F_{\max}$ , bodies slip.

$$(f_1)_{\max} = \mu m_B g = (0.1) \times \frac{3}{2} m \times g = 0.15 \text{ mg}$$

$$(f_2)_{\max} = \mu m_A g = (0.2) \left( \frac{m}{2} \right) (g) = 0.1 \text{ mg}$$

Hence, minimum force required, so that both the blocks will move together,

$$\begin{aligned} F_{\min} &= (f_1)_{\max} + (f_2)_{\max} \\ &= 0.15 \text{ mg} + 0.1 \text{ mg} = 0.25 \text{ mg} \end{aligned}$$

- (d) According to the problem, force  $F = 0.1$  mg  $< F_{\min}$   
 Hence, the bodies will be at rest.  
 (e) Maximum force for combined movement  $F_{\max} = 0.45$  mg.

Q12. Mass  $m_1$  moves on a slope making an angle  $\theta$  with the horizontal and is attached to mass  $m_2$  by a string passing over a frictionless pulley as shown in figure. The coefficient of friction between  $m_1$  and the sloping surface is  $\mu$ . Which of the following statements are true?

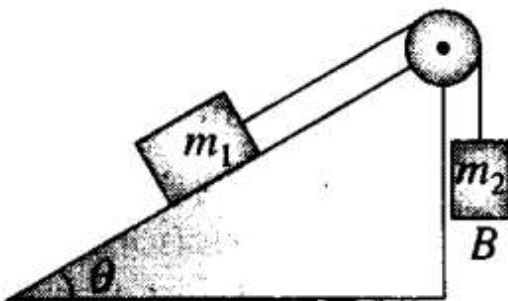

- (a) If  $m_2 > m_1 \sin \theta$ , the body will move up the plane.  
 (b) If  $m_2 > m_1 (\sin \theta + \mu \cos \theta)$ , the body will move up the plane.  
 (c) If  $m_2 < m_1 (\sin \theta + \mu \cos \theta)$ , the body will move up the plane.  
 (d) If  $m_2 < m_1 (\sin \theta - \mu \cos \theta)$ , the body will move down the plane.

**Sol:** (b, d)

Key concept: When a mass  $m_1$  is placed on a rough inclined plane: Another mass  $m_2$  hung from the string connected by frictionless pulley, the tension ( $T$ ) produced in string will try to start the motion of mass  $m_1$ . At limiting condition,

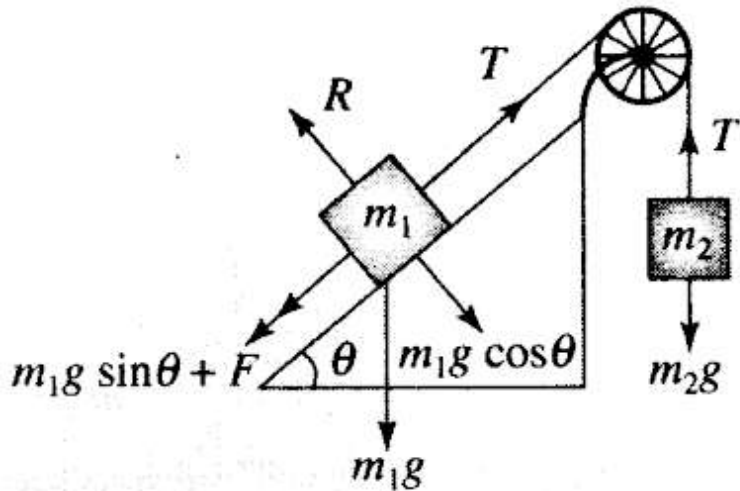

For  $m_2$   $T = m_2g$  ... (i) ,

For  $m_1$   $T = m_1g \sin \theta + F$

$\Rightarrow T = m_1g \sin \theta + \mu R$

$\Rightarrow T = m_1g \sin \theta + \mu m_1g \cos \theta$

From equation (i) and (ii),  $m_2 = m_1[\sin \theta + \mu \cos \theta]$

This is the minimum value of  $m_2$  to start the motion.

**Note:** In the above condition, Coefficient of friction  $\mu = \left[ \frac{m_2}{m_1 \cos \theta} - \tan \theta \right]$

Simplified situation is shown in the diagram.

Let  $m_1$  moves up the plane. Different forces involved are shown in the diagram.

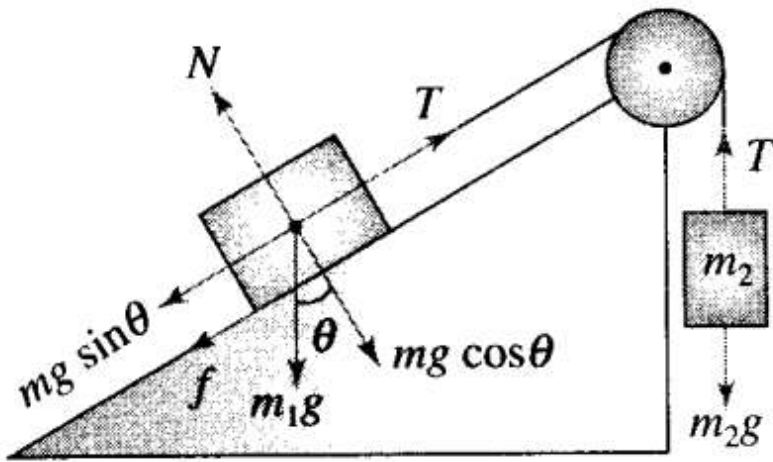

$N$  = Normal reaction between wedge and block  $m_1$

$f$  = Frictional force between wedge and block  $m_1$

$T$  = Tension in the string

$$f = \mu N = \mu m_1 g \cos \theta$$

For the system  $(m_1 + m_2)$ , condition for  $m_1$  to move up the inclined plane.

$$m_2 g - (m_1 g \sin \theta + f) > 0$$

$$\Rightarrow m_2 g - (m_1 g \sin \theta + \mu m_1 g \cos \theta) > 0$$

$$\Rightarrow m_2 > m_1 (\sin \theta + \mu \cos \theta)$$

Hence, option (b) is correct.

Condition for  $m_1$  to move down the inclined plane. In this case friction  $f$  acts up the plane.

$$\text{Hence, } m_1 g \sin \theta - f > m_2 g$$

$$\Rightarrow m_1 g \sin \theta - \mu m_1 g \cos \theta > m_2 g$$

$$\Rightarrow m_1 (\sin \theta - \mu \cos \theta) > m_2$$

$$\Rightarrow m_2 < m_1 (\sin \theta - \mu \cos \theta)$$

Hence, option (d) is correct.

**Q13.** In figure a body A of mass  $m$  slides on a plane inclined at angle  $\theta_1$  to the horizontal and  $\mu$  is the coefficient of friction between A and the plane. A is connected by a light string passing over a frictionless pulley to another body B, also of mass  $m$ , sliding on a frictionless plane inclined at an angle  $\theta_2$  to the horizontal. Which of the following statements are true?



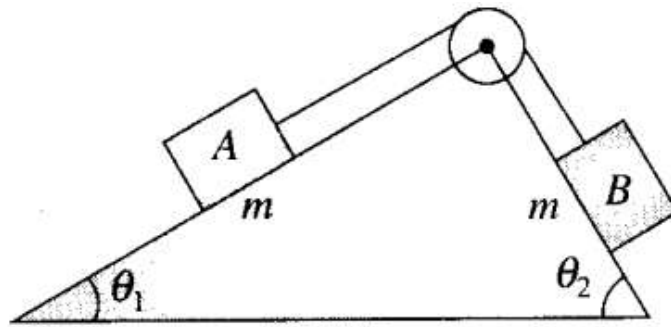

- (a)  $A$  will never move up the plane.
- (b)  $A$  will just start moving up the plane when  $\mu = \frac{\sin \theta_2 - \sin \theta_1}{\cos \theta_1}$ .
- (c) For  $A$  to move up the plane,  $\theta_2$  must always be greater than  $\theta_1$ .
- (d)  $B$  will always slide down with constant speed.

**Sol:** (b, c)

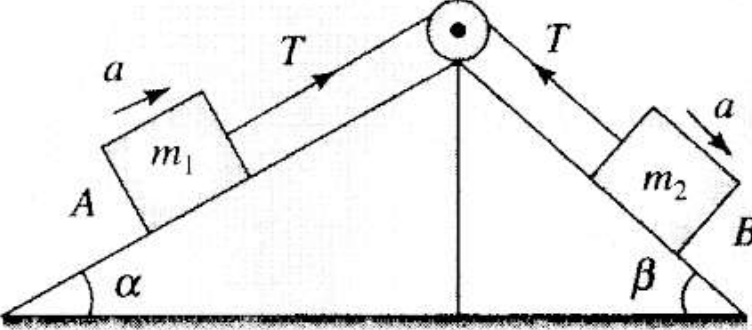
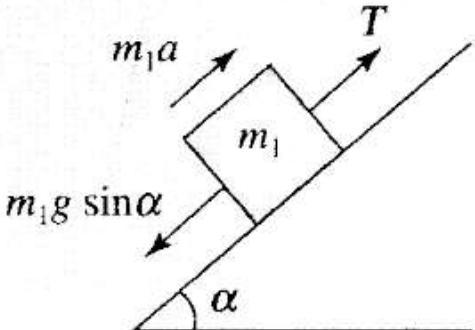
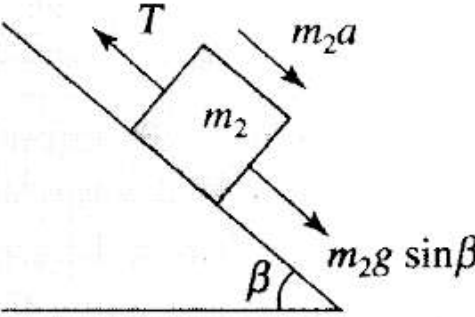
Condition	Free body diagrams	
		
Equation	Tension and acceleration	
$T - m_1 g \sin \alpha = m_1 a$	$a = \frac{(m_2 \sin \beta - m_1 \sin \alpha)}{m_1 + m_2} g$	
$m_2 a = m_2 g \sin \beta - T$	$T = \frac{m_1 m_2 (\sin \alpha + \sin \beta)}{m_1 + m_2} g$	

In this problem first we have to decide the direction of motion. Let block A moves up the plane friction force on A will be downward (along the plane) as shown.

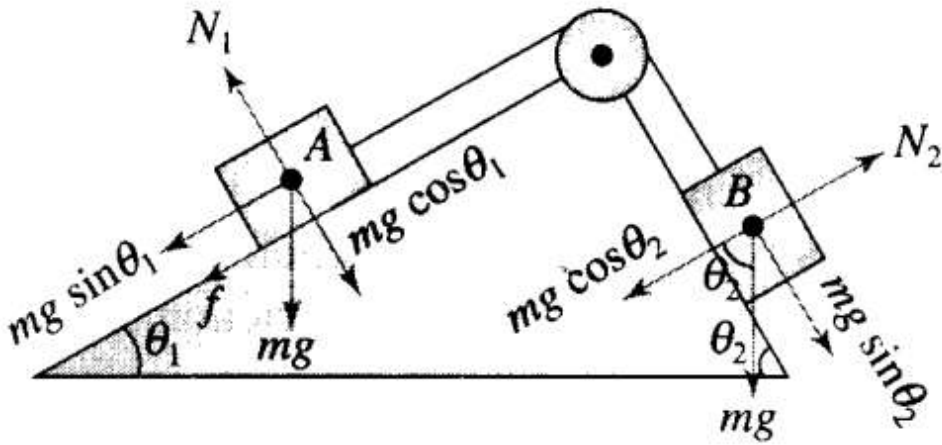

The block  $A$  will just starts moving up if,

$$mg \sin \theta_1 + f = mg \sin \theta_2$$

$$\Rightarrow mg \sin \theta_1 + \mu mg \cos \theta_1 = mg \sin \theta_2$$

$$\Rightarrow \mu = \frac{\sin \theta_2 - \sin \theta_1}{\cos \theta_1}$$

When block  $A$  moves upwards

$$f = mg \sin \theta_2 - mg \sin \theta_1 > 0$$

$$\sin \theta_2 > \sin \theta_1 \Rightarrow \theta_2 > \theta_1$$

Q14. Two billiard balls A and B, each of mass  $50 \text{ g}$  and moving in opposite directions with speed of  $5 \text{ m s}^{-1}$  each, collide and rebound with the same speed. If the collision lasts for  $10^{-3} \text{ s}$ , which of the following statements are true?

The impulse imparted to each ball is  $0.25 \text{ kg}\cdot\text{m s}^{-1}$  and the force on each ball is  $250 \text{ N}$ .

- (a) The impulse imparted to each ball is  $0.25 \text{ kg}\cdot\text{m s}^{-1}$  and the force exerted on each ball is  $25 \times 10^5$
- (b) The impulse imparted to each ball is  $0.5 \text{ N}\cdot\text{s}$ .
- (c) The impulse and the force on each ball are equal in magnitude and opposite in directions.

**Sol. (c, d)**

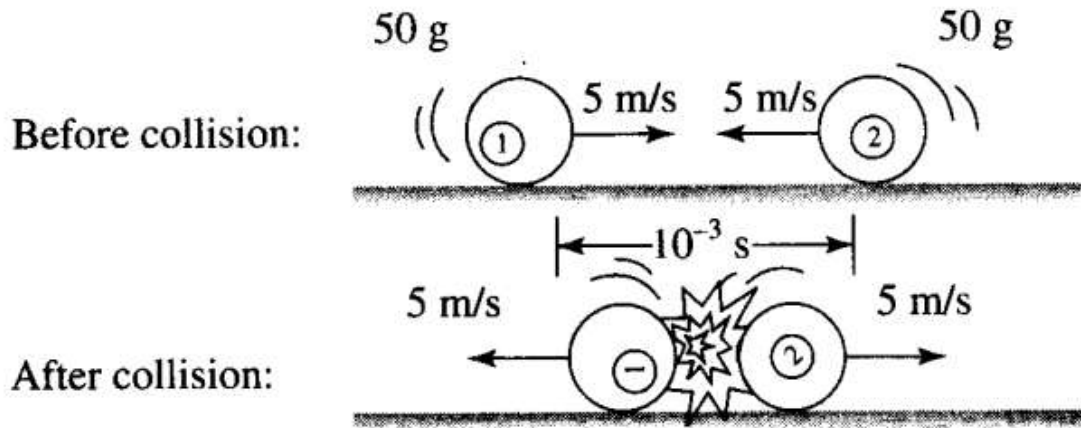

According to the problem, balls are identical.

$$m_1 = m_2 = 50(\text{g}) = \frac{50}{1000} \text{ kg} = \frac{1}{20} \text{ kg}$$

Initial velocity ( $u$ ) =  $u_1 = u_2 = 5$  m/s

Final velocity ( $v$ ) =  $v_1 = v_2 = -5$  m/s

Time duration of collision =  $10^{-3}$  s

Change in linear momentum =  $m(v - u)$

$$= \frac{1}{20} [-5 - 5] = -0.5 \text{ N}\cdot\text{s}$$

$$\begin{aligned} \text{Force} &= \frac{I}{\Delta T} = \frac{\Delta P}{\Delta T} \\ &= \frac{0.5}{10^{-3}} = 500 \text{ N} \end{aligned}$$

Impulse and force are opposite in directions.

**Q15.** A body of mass 10 kg is acted upon by two perpendicular forces, 6 N and 8 N. The resultant acceleration of the body is

(a)  $1 \text{ ms}^{-2}$  at an angle of  $\tan^{-1}\left(\frac{4}{3}\right)$  w.r.t. 6 N force.

(b)  $0.2 \text{ m s}^{-2}$  at an angle of  $\tan^{-1}\left(\frac{4}{3}\right)$  w.r.t. 6 N force.

(c)  $1 \text{ m s}^{-2}$  at an angle of  $\tan^{-1}\left(\frac{3}{4}\right)$  w.r.t. 8 N force.

(d)  $0.2 \text{ m s}^{-2}$  at an angle of  $\tan^{-1}\left(\frac{3}{4}\right)$  w.r.t. 8 N force.

**Sol:** (a, c) Recall the concept of resultant of two vectors, when they are perpendicular

$$R = \sqrt{A^2 + B^2 + 2AB \cos \theta}$$

As they are perpendicular,  $\cos 90^\circ = 0$

So resultant will be  $R = \sqrt{A^2 + B^2}$

As shown in the diagram

According to the problem, mass =  $m = 10 \text{ kg}$

$$F_1 = 6 \text{ N}, F_2 = 8 \text{ N}$$

Net force =  $F = \sqrt{F_1^2 + F_2^2} = \sqrt{36 + 64} = 10 \text{ N}$

$$a = \frac{F}{m} = \frac{10}{10} = 1 \text{ m/s}^2 \text{ along } F.$$

Let  $\theta_1$  be the angle between  $F$  and  $F_1$ .

$$\tan \theta_1 = \frac{8}{6} = \frac{4}{3}$$

$$\theta_1 = \tan^{-1}\left(\frac{4}{3}\right) \text{ w.r.t } F_1 = 6 \text{ N}$$

Let  $\theta_2$  be angle between  $F$  and  $F_2$ .

$$\tan \theta_2 = \frac{6}{8} = \frac{3}{4}$$

$$\theta_2 = \tan^{-1}\left(\frac{3}{4}\right) \text{ w.r.t } F_2 = 8 \text{ N}$$

