

## Multiple Choice Questions

### Single Correct Answer Type

Q1. Among the four graphs shown in the figure, there is only one graph for which average velocity over the time interval  $(0, T)$  can vanish for a suitably chosen  $T$ . Which one is it?

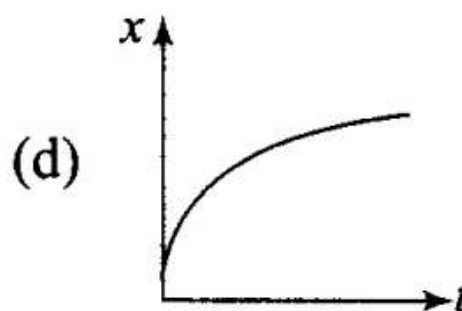
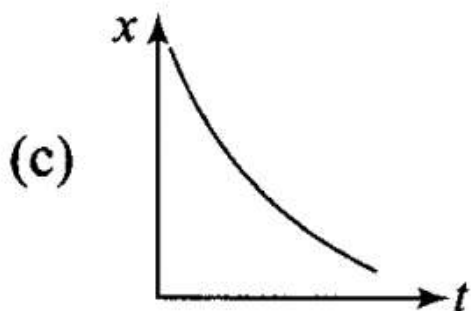
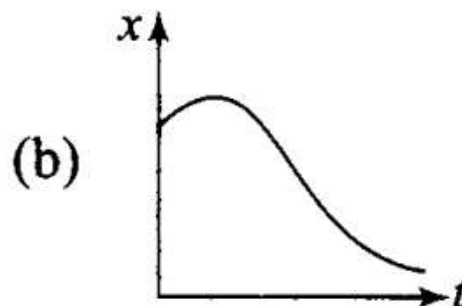
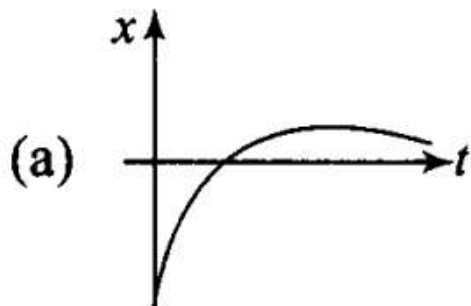

Key concept: Average velocity : It is defined as the ratio of displacement to time taken by the body.

Displacement / Time taken

According to this problem, we need to identify the graph which is having same displacement for two timings. When there are two timings for same displacement, the corresponding velocities should be in opposite directions.

As shown in graph (b), the first slope is decreasing that means particle is going in one direction and its velocity decreases, becomes zero at highest point of curve and then increasing in backward direction.

Hence the particle

return to its initial position. So, for one value of displacement there are two different points of time and we know that slope of  $x$ ,  $x$ - $t$  graph gives us the average velocity. Hence, for one time, slope is positive then average velocity is  $A$  also positive and for other time slope is negative then average velocity is also negative.

As there are opposite velocities in the interval  $0$  to  $T$ , hence average velocity can vanish in (b).

This can be seen in the figure given alongside.

As shown in the graph,  $OA = BT$  (same displacement) for two different points of time.

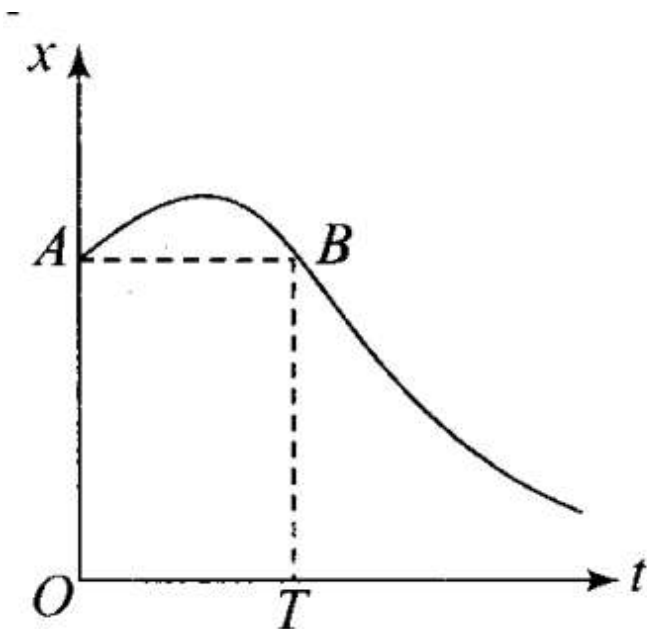

### Important points:

Various position-time graphs and their interpretation

1. Graph: Line parallel to time axis

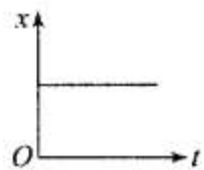

Interpretation: It represents that the particle is at rest.

2. Graph: Line perpendicular to time axis

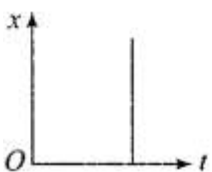

Interpretation: It represents that particle is changing its position but time does not change, it means the particle possesses infinite velocity.

This situation is practically not possible.

3. Graph: Line with constant slope

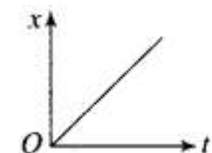

Interpretation: It represents uniform velocity of the particle.

4. Graph: Parabola bending towards position axis

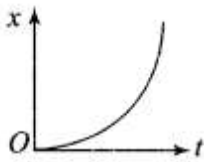

Interpretation: It represents increasing velocity of the particle. It means the particle possesses acceleration. Hence slope of position-time graph goes on increasing.

5. Graph: Parabola bending towards time axis

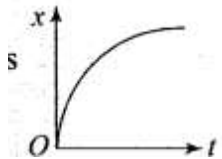

Interpretation: It represents decreasing velocity of particle. It means the particle possesses retardation. Hence slope of position-time graph goes on decreasing.

6. Graph: Line with negative slope

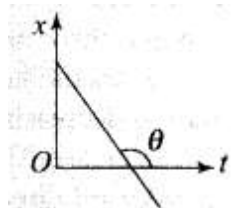

Interpretation: It represents that the particle returns towards the point of reference (negative displacement) with uniform velocity.

**2. A lift is coming from 8th floor and is just about to reach 4th floor. Taking ground floor as origin and positive direction upwards for all quantities, which one of the following is correct?**

**(a)  $x < 0, v < 0, a > 0$  (b)  $x > 0, v < 0, a < 0$**

**(c)  $x > 0, v < 0, a > 0$  (d)  $x > 0, v > 0, a < 0$**

**Sol:**(a)

Key concept: The time rate of change of velocity of an object is called acceleration of the object.

It is a vector quantity. Its direction is same as that of change in velocity (Not of the velocity).

In the table: Possible ways of velocity change

When only direction of velocity changes	When only magnitude of velocity changes	When both magnitude and direction of velocity change
Acceleration perpendicular	Acceleration parallel or anti-	Acceleration has two components—one is

to velocity	parallel to velocity	perpendicular to velocity and another parallel or antiparallel to velocity
E.g.: Uniform circular motion	E.g.: Motion under gravity	E.g: Projectile motion

Here we will take upward direction positive. As the lift is coming in downward direction, the displacement will be negative. We have to see whether the motion is accelerating or retarding.

We know that due to downward motion displacement will be negative. When the lift reaches 4th floor and is about to stop velocity is decreasing with time, hence motion is retarding in nature. Thus,  $x < 0$ ;  $a > 0$ .

As displacement is in negative direction, velocity will also be negative, i.e.  $v < 0$ .

The motion of lift will be shown like this.

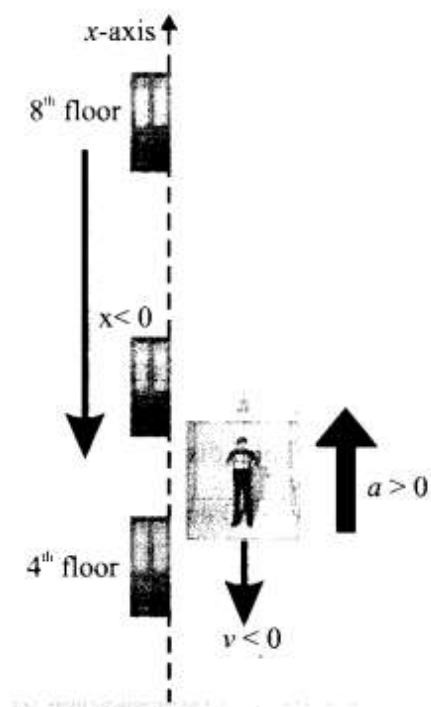

**Q3. In one dimensional motion, instantaneous speed  $v$  satisfies  $0 < v < v_0$**

**(a) The displacement in time  $T$  must always take non-negative values.**

**(b) The displacement  $x$  in time  $T$  satisfies  $-v_0 T < x < v_0$**

**(c) The acceleration is always a non-negative number.**

**(d) The motion has no turning points.**

**Sol:** (b) .

Key concept: Instantaneous speed: It is the speed of a particle at a particular instant of time. When we say

“speed”, it usually means instantaneous speed. The instantaneous speed is average speed for infinitesimally small time interval (i.e.,  $\Delta t \rightarrow 0$ ).

Thus, Instantaneous speed  $v = \lim_{\Delta t \rightarrow 0} \frac{\Delta s}{\Delta t} = \frac{ds}{dt}$

As instantaneous speed is less than maximum speed. Then either the velocity is increasing or it is decreasing. For maximum and minimum displacement we have to keep in mind the magnitude and direction of maximum velocity.

As maximum velocity in positive direction is  $v_0$ , magnitude of maximum velocity in opposite direction is also  $v_0$ .

Maximum displacement in one direction =  $v_0T$  Maximum displacement in opposite directions =  $-v_0T$  Hence,  $-v_0T < x < v_0T$ .

**Important point:** We should not confuse with direction of velocities, i.e., in one direction it is taken as positive and in another direction it is taken as negative.

**Q4. A vehicle travels half the distance  $L$  with speed  $V_1$  and the other half with speed  $v_2$ , then its average speed is**

(a)  $\frac{v_1 + v_2}{2}$

(b)  $\frac{2v_1 + v_2}{v_1 + v_2}$

(c)  $\frac{2v_1v_2}{v_1 + v_2}$

(d)  $\frac{L(v_1 + v_2)}{v_1v_2}$

**Sol. (c)** Consider the diagram below in which motion is as shown below.

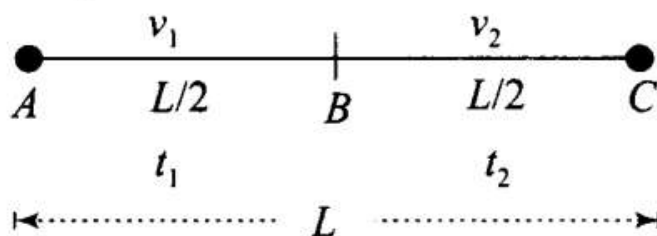

Let the vehicle travels from A to B. Distances, velocities and time taken are shown. To calculate average speed we will calculate total distance covered and will divide by time interval in which it covers that total

distance.

$$\text{Time taken to travel first half distance } t_1 = \frac{L/2}{v_1} = \frac{L}{2v_1}$$

$$\text{Time taken to travel second half distance } t_2 = \frac{L}{2v_2}$$

$$\text{Total time} = t_1 + t_2$$

$$= \frac{L}{2v_1} + \frac{L}{2v_2} = \frac{L}{2} \left[ \frac{1}{v_1} + \frac{1}{v_2} \right]$$

We know that

$$v_{av} = \text{Average speed} \\ = \text{total distance/total time}$$

$$v_{av} = \frac{L}{\frac{L}{2} \left[ \frac{1}{v_1} + \frac{1}{v_2} \right]} = \frac{2v_1v_2}{v_1 + v_2}$$

**Important point:** Students usually thought that  $v_{av} = \frac{v_1 + v_2}{2}$  but it is not the average speed when two equal distances are covered by speed  $v_1$  and  $v_2$ .

**Remember:** If  $t_1 = t_2 = t$ , then  $v_{av} = \frac{v_1 + v_2}{2}$ . Average speed is equal to arithmetical mean of individual speeds. (if the particle moves in equal interval of times at different speeds  $v_1$  and  $v_2$ .)

And also we should not confuse with distance and displacement.  
Distance  $\geq$  Displacement.

Q5. The displacement of a particle is given by  $x = (t - 2)^2$  where  $x$  is in metres and  $t$  in seconds. The distance covered by the particle in first 4 seconds is

- (a) 4 m
- (b) 8 m
- (c) 12 m

(d) 16 m

Sol: (b)

Key concept: Instantaneous velocity : Instantaneous velocity is defined as the rate of change of position vector of particles with time at a certain instant of time.

$$\text{Instantaneous velocity } \vec{v} = \lim_{\Delta t \rightarrow 0} \frac{\Delta \vec{r}}{\Delta t} = \frac{d\vec{r}}{dt}$$

$$\text{Instantaneous acceleration} = \vec{a} = \lim_{\Delta t \rightarrow 0} \frac{\Delta \vec{v}}{\Delta t} = \frac{d\vec{v}}{dt}$$

$$\text{By definition } \vec{a} = \frac{d\vec{v}}{dt} = \frac{d^2 \vec{x}}{dt^2} \left[ \text{As } \vec{v} = \frac{d\vec{x}}{dt} \right]$$

i.e., if  $x$  is given as a function of time, second time derivative of displacement gives acceleration.

In such type of problems we have to analyze whether the motion is accelerating or retarding. When acceleration is parallel to velocity, velocity of particle increases with time, i.e. motion is accelerated. And when acceleration is anti-parallel to velocity, velocity of particle decreases with time, i.e. motion is retarded. During retarding journey, particle will stop in between.

According to the problem, displacement of the particle is given as a function of time.

$$x = (t-2)^2$$

By differentiating this equation w.r.t. time we get velocity of the particle as a function of time.

$$v = dx/dt = d/dt (t-2)^2 = 2(t-2) \text{ m/s}$$

If we again differentiate this equation w.r.t. time we will get acceleration of the particle as a function of time.

$$\begin{aligned} \text{Acceleration, } a &= \frac{dv}{dt} = \frac{d}{dt}[2(t-2)] \\ &= 2[1-0] = 2 \text{ m/s}^2 \end{aligned}$$

When  $t = 0$ ;  $v = -4 \text{ m/s}$

$t = 2 \text{ s}$ ;  $v = 0 \text{ m/s}$

$t = 4 \text{ s}$ ;  $v = 4 \text{ m/s}$

That means particle starts moving towards negative axis, then at  $t = 0$ , with a speed  $4 \text{ m/s}$ , at  $t = 2$  it stops and start coming backward. At  $t = 4$  its speed is  $+4 \text{ m/s}$ .

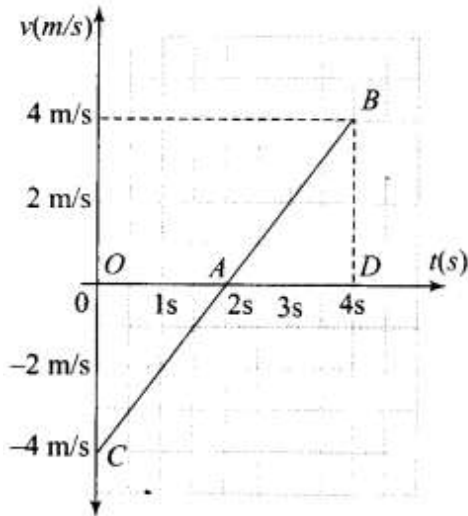

Fig. (a)

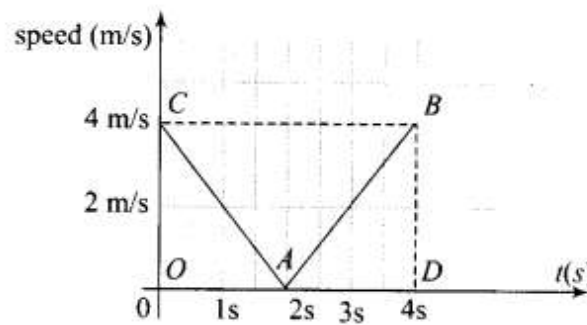

Fig. (b)

$v-t$  graph is shown in graph (a) and speed-time graph of the same situation is shown in graph (b).

Distance travelled = Area of the speed-time graph

$$= \text{area } OAC + \text{area } ABD$$

$$= \frac{4 \times 2}{2} + \frac{1}{2} \times 2 \times 4 = 8 \text{ m}$$

**Q6.** At a metro station, a girl walks up a stationary escalator in time  $t_1$ . If she remains stationary on the escalator, then the escalator takes her up in time  $t_2$ . The time taken by her to walk up on the moving escalator will be

(a)  $(t_1+t_2)/2$  (b)  $t$

(b)  $t_1 t_2 / (t_2 - t_1)$

(c)  $t_1 t_2 / (t_2 + t_1)$

(d)  $t_1 - t_2$

Sol: (c)

Key concept: Net velocity when object is moving on the moving frame in One Dimension:

We will define this concept by taking an example.



River-Man problem in one dimension:

Velocity of river water current is  $u$  and velocity of man in still water is  $v$ , i.e. man can swim in water with velocity  $v$ .

### Case-1

Man swimming downstream (along the direction of river flow)

In this case velocity of river  $\vec{v}_R = +u$

velocity of man w.r.t. river  $\vec{v}_{mR} = +v$ .

Now  $\vec{v}_m = \vec{v}_{mR} + \vec{v}_R = u + v$

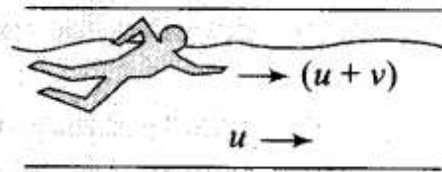

### Case-2

Man swimming upstream (opposite to the direction of river flow)

In this case velocity of river  $\vec{v}_R = -u$

velocity of man w.r.t. river  $\vec{v}_{mR} = +v$

Now  $\vec{v}_m = \vec{v}_{mR} + \vec{v}_R = (v - u)$

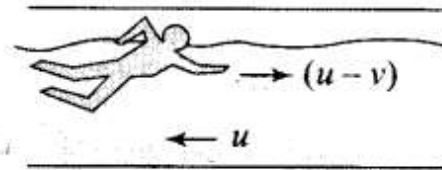

In this problem, we have to observe the motion from different frames. We have to find net velocity with respect to the Earth that will be equal to velocity of the girl plus velocity of escalator. Let displacement is  $L$ , then

Velocity of girl  $v_g = \frac{L}{t_1}$

Velocity of escalator  $v_e = \frac{L}{t_2}$

Net velocity of the girl seen from ground when walk up on the moving escalator

$= v_g + v_e = \frac{L}{t_1} + \frac{L}{t_2}$

If  $t$  is total time taken in covering distance  $L$ , then

$$\frac{L}{t} = \frac{L}{t_1} + \frac{L}{t_2} \Rightarrow t = \frac{t_1 t_2}{t_1 + t_2}$$

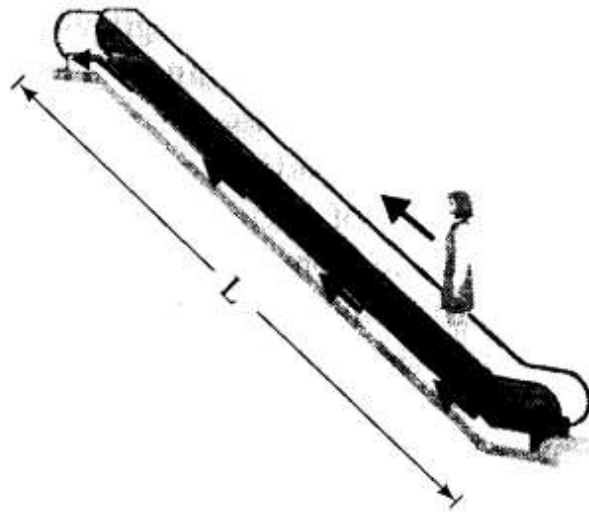

### Problem-Solving Tips for Relative Velocity

- If the velocity is mentioned without specifying the frame, assume it is with respect to the ground.
- In many cases, a body travels on water or in air. Depending on the context you will have to figure out whether the velocity is with respect to the water/air or with respect to the ground.

- In some situations you have to presume the velocities. For example, if the problem says that a man can walk at a maximum of  $8 \text{ km h}^{-1}$  and if it asks you to find the velocity on a train, then you have to assume that the velocity of the man with respect to the surface he is on (in this case the tram is  $8 \text{ km h}^{-1}$ ). Similarly the velocity of a bullet is always measured with respect to the gun. If the gun is mounted on a truck, the bullet will have a different velocity.

**If particle is moving with constant velocity towards right (+x-axis):**

Equation to be used:  $x = x_0 + vt$ . Graph will be a straight line.

Let the particle be at some point P initially at time  $t = 0$  which is at a distance of  $x_0$  from origin. Since the particle is moving towards right so its distance from origin goes on increasing. Hence position-time graph for a particle moving with constant velocity towards right will be a straight line inclined to time axis making an acute angle  $\alpha$ .

Recall that  $\tan \alpha$  is slope of position-time graph which is equal to velocity of the particle.

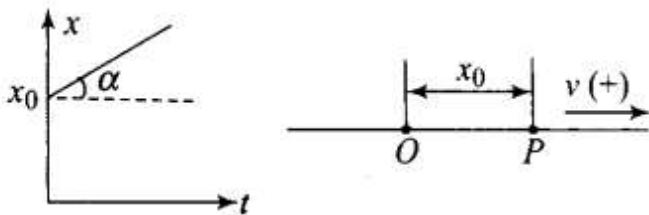

For uniform motion velocity is constant, hence slope will be positive. Hence quantity A is displacement.

If particle is moving with a constant positive acceleration:

Equation to be used:  $v = u + at$

As the time passes velocity goes on increasing. Hence velocity-time graph for a particle moving with constant positive acceleration is a straight line inclined to time axis making an acute angle  $\alpha$ . Here  $\tan \alpha$  is the slope of velocity-time graph (Figure).

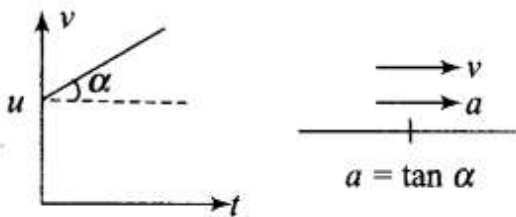

For uniformly accelerated motion, slope will be positive and A will represent velocity.

**Q9. A graph of x versus t is shown in figure.**

Choose the correct alternatives given below.

- (a) The particle was released from rest at  $t = 0$
- (b) At B, the acceleration  $a > 0$
- (c) At C, the velocity and the acceleration vanish.
- (d) Average velocity for the motion between A and D is positive.
- (e) The speed at D exceeds that at E

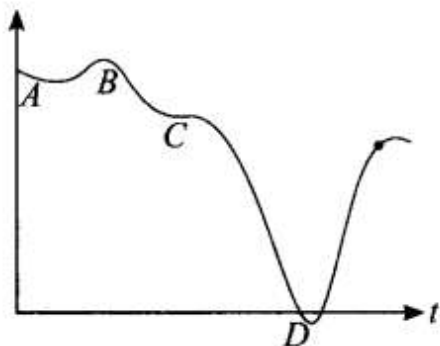

**Sol:** (a, c, e)

Key concept: We know that velocity  $v = dx/dt$  and slope of  $x-t$  graph gives us velocity. This implies slope =  $dx/dt$  for the graph.

As per the diagram, at point A the graph is parallel to time axis, hence  $dx/dt = 0$ . As the starting point is A, hence we can say that the particle is starting from rest. Thus option (a) is correct.

At C, the graph changes slope, hence velocity also changes. As graph at C is almost parallel to time axis, hence we can say that velocity vanishes. Hence option (c) is correct.

As direction of acceleration changes, hence we can say that it may be zero in between.

From the graph it is clear that  $|\text{slope at D}| > |\text{slope at E}|$

Hence, speed at D will be more than at E. Hence option (e) is correct.

Important point: Here, negative slope does not mean less value. It represents change in direction of velocity.

**Q9. For the one-dimensional motion, described by  $x = t - \sin t$ .**

- (a)  $x(t) > 0$  for all  $t > 0$
- (b)  $v(t) > 0$  for all  $t > 0$
- (c)  $a(t) > 0$  for all  $t > 0$
- (d)  $v(t)$  lies between 0 and 2

**Sol:** (a, d) Position of the particle is given as a function of time i.e.  $x = t - \sin t$  By differentiating this equation w.r.t. time we get velocity of the particle as a function of time.

$$\text{Velocity } v = \frac{dx}{dt} = \frac{d}{dt}[t - \sin t] = 1 - \cos t$$

If we again differentiate this equation w.r.t. time we will get acceleration of the particle as a function of time.

$$\text{Acceleration } a = \frac{dv}{dt} = \frac{d}{dt}[1 - \cos t] = \sin t$$

As acceleration  $a > 0$  for all  $t > 0$

Hence,  $x(t) > 0$  for all  $t > 0$

Velocity  $v = 1 - \cos t$

When,  $\cos t = 1$ , velocity  $v = 0$

$$v_{\max} = 1 - (\cos t)_{\min} = 1 - (-1) = 2$$

$$v_{\min} = 1 - (\cos t)_{\max} = 1 - 1 = 0$$

Hence,  $v$  lies between 0 and 2.

Acceleration  $a = \frac{dv}{dt} = -\sin t$

When  $t = 0$ ;  $x = 0$ ,  $v = 0$ ,  $a = 0$

When  $t = \frac{\pi}{2}$ ;  $x = \text{positive}$ ,  $v = 0$ ,  $a = -1$  (negative)

When  $t = \pi$ ,  $x = \text{positive}$ ,  $v = \text{positive}$ ,  $a = 0$

When  $t = 2\pi$ ,  $x = 0$ ,  $v = 0$ ,  $a = 0$

#### Important points:

- (i) When sinusoidal function is involved in an expression we should be careful about sine and cosine functions.
- (ii) We should be very careful when calculating maximum and minimum value of velocity because it is in inverse relation with cost in the given expression.

**Q10. A spring with one end attached to a mass and the other to a rigid support is stretched and released.**

- (a) Magnitude of acceleration, when just released is maximum.
- (b) Magnitude of acceleration, when at equilibrium position, is maximum.
- (c) Speed is maximum when mass is at equilibrium position.
- (d) Magnitude of displacement is always maximum whenever speed is minimum

Sol:(a, c)

Sol. (a, c)

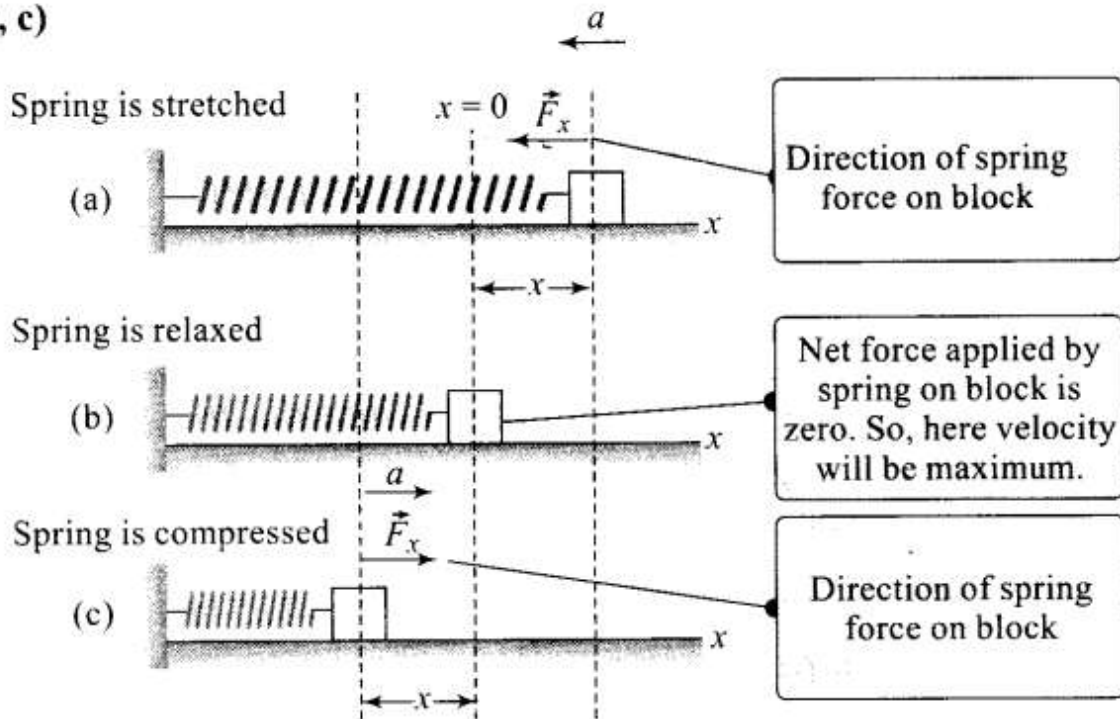

As shown in the figure above when spring is stretched by length  $x$ , restoring force will be  $F = -kx$  ( $-ve$  sign shows that the force is always in the direction opposite to displacement  $x$ ). Then the potential energy of the stretched spring

$$= PE = \frac{1}{2}kx^2$$

The restoring force is central, hence when particle is released it will execute Simple Harmonic Motion about equilibrium position.

Acceleration will be  $a = \frac{F}{m} = \frac{-kx}{m}$

At equilibrium position,  $x = 0 \Rightarrow a = 0$

Hence, when just released  $x = x_{\max}$

Hence, acceleration is maximum. Thus option (a) is correct.

At equilibrium whole PE will be converted to KE, so KE will be maximum and hence, speed will be maximum. Thus option (c) is correct.

Q11. A ball is bouncing elastically with a speed 1 m/s between walls of a railway compartment of size 10 m in a direction perpendicular to the walls. The train is moving at a constant velocity of 10 m/s parallel to the direction of motion of the ball. As seen from the ground,

(a) the direction of motion of the ball changes every 10 seconds.

(b) speed of ball changes every 10 seconds.

(c) average speed of ball over any 20 second interval is fixed.

(d) the acceleration of ball is the same as from the train.

**Sol: (b, c, d)** In this problem, we have to observe the motion from different frames. Here the problem can be solved by the frame of the observer but here we must be clear that we are considering the motion from the ground so we just keep in mind the motion from frame of observer. Compared to the velocity of trains (10 m/s) speed of ball is less (1 m/s).

(b, c, d) In this problem, we have to observe the motion from different frames. Here the problem can be solved by the frame of the observer but here we must be clear that we are considering the motion from the ground so we just keep in mind the motion from frame of observer. Compared to the velocity of trains (10 m/s) speed of ball is less (1 m/s).

The speed of the ball before collision with side of train is  $10 + 1 = 11$  m/s Speed after collision with side of train  $= 10 - 1 = 9$  m/s As speed is changing after travelling 10 m and speed is 1 m/s, hence time duration of the changing speed is 10 s.

Since, the collision of the ball is perfectly elastic there is no dissipation of energy, hence total momentum and kinetic energy are conserved.

Since, the train is moving with a constant velocity, hence it will act as an inertial frame of reference as that of Earth and acceleration will be same in both frames.

Remember: We should not confuse with non-inertial and inertial frame of reference. A frame of reference that is not accelerating will be inertial.

### Very Short Answer Type Questions

12. Match the following.

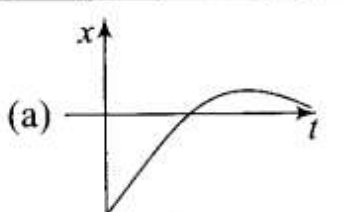
Graph	Characteristics
(a) 	(i) has $v > 0$ and $a > 0$ throughout

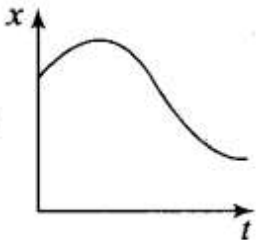
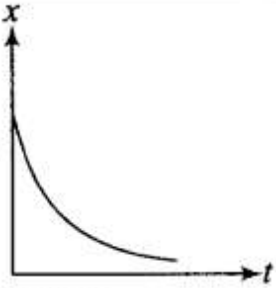
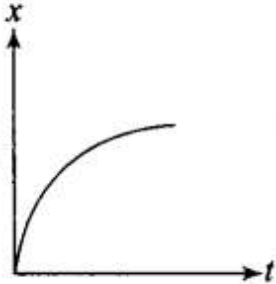
<p>(b)</p> 	<p>(ii) has <math>x &gt; 0</math> throughout and has a point with <math>v = 0</math> and a point with <math>a = 0</math></p>
<p>(c)</p> 	<p>(iii) has a point with zero displacement for <math>t &gt; 0</math></p>
<p>(d)</p> 	<p>(iv) has <math>v &lt; 0</math> and <math>a &gt; 0</math></p>

**Key concept:**

- The slope of  $x-t$  graph gives us velocity  $v = \frac{dx}{dt}$ . If the slope of  $x-t$  graph is constant, it represents constant velocity.
- The changing slope of  $x-t$  graph represents accelerated motion.
- If slope of  $x-t$  graph is increasing, i.e. curve bending towards position axis, the velocity of the particle will increase or we can say the particle possesses acceleration.
- If slope of  $x-t$  graph is decreasing, i.e. curve bending towards time axis, the velocity of the particle will decrease or we can say the particle possesses retardation.
- For highest or lowest points on  $x-t$  graph  $\frac{dx}{dt}$ , will be zero, represents zero velocity. At highest position of curve  $\frac{d^2x}{dt^2} < 0$ , represents negative acceleration. At lowest position of curve  $\frac{d^2x}{dt^2} > 0$ , represents positive acceleration.
- If  $x-t$  graph opens up,  $\frac{d^2x}{dt^2} > 0$ , represents positive acceleration.
- If  $x-t$  graph opens down,  $\frac{d^2x}{dt^2} < 0$ , represents negative acceleration.
- At any point on  $x-t$  graph if the curvature changes, the acceleration on such points will be zero.

Ans. (a) (iii); (b) (ii); (c) (iv); (d) - (i)

Sol: Let us pick graphs one by one.

In graph (a),

There is a point (B) on the curve for which displacement is zero. So curve, (a) matches with (iii).



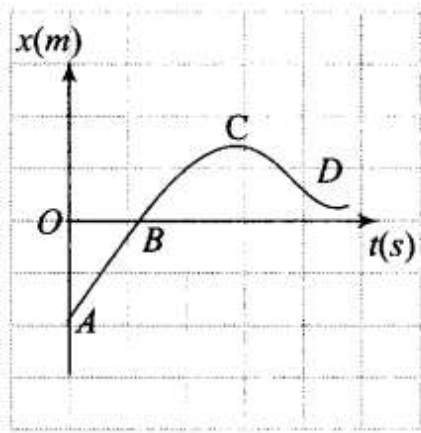

In graph (b),

In this graph,  $x$  is positive ( $> 0$ ) throughout and at point  $B$  the highest point of curve the slope of curve is zero. It means at

this point  $v = dx/dt = 0$ . Also at point  $C$  the  $dt$

curvature changes, it means at this point the acceleration of the particle should be zero or  $a = 0$ , So curve

(b) matches with (ii).

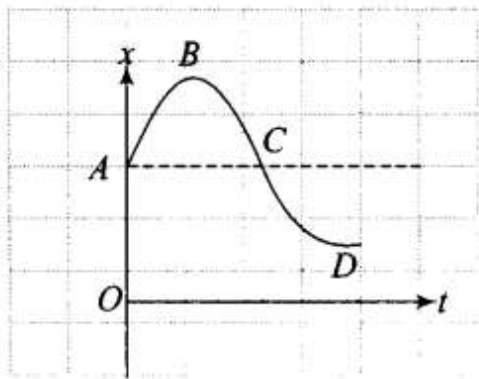

In graph (c),

In this graph the slope is always negative, hence velocity will be negative or  $v < 0$ . Also  $x$ - $t$  graph opens up, it represents positive acceleration. So curve (c) matches with (iv).

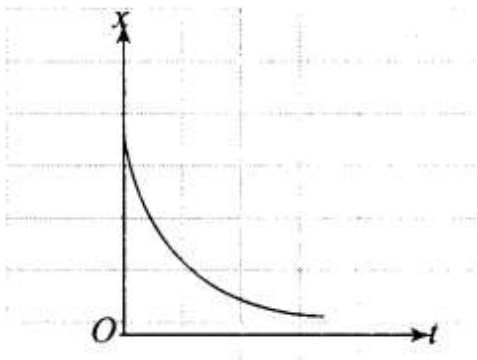

In graph (d),

In this graph the slope is always positive, hence velocity will be positive or  $v > 0$ . Also  $x$ - $t$  graph opens down, it represents negative acceleration. So curve (d) matches with (i).

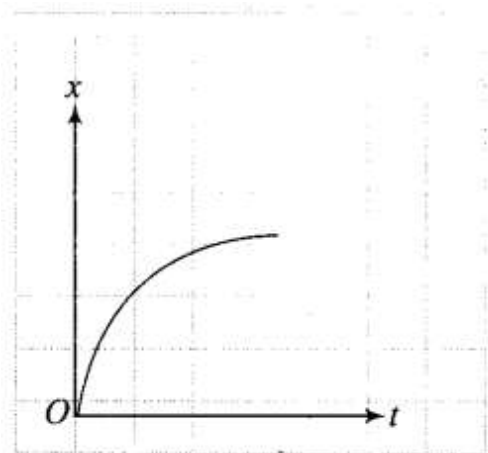

**13. A uniformly moving cricket ball is turned back by hitting it with a bat for a very short time interval. Show the variation of its acceleration with time (Take acceleration in the backward direction as positive).**

**Sol:** Impulsive Force is generated by the bat: If we ignore the effect of gravity just by analyzing the motion of ball in horizontal direction only, then ball moving uniformly will return back with the same speed when a bat hits it.

Acceleration of the ball is zero just before it strikes the bat. When the ball strikes the bat, it gets accelerated due to the applied impulsive force by the bat.

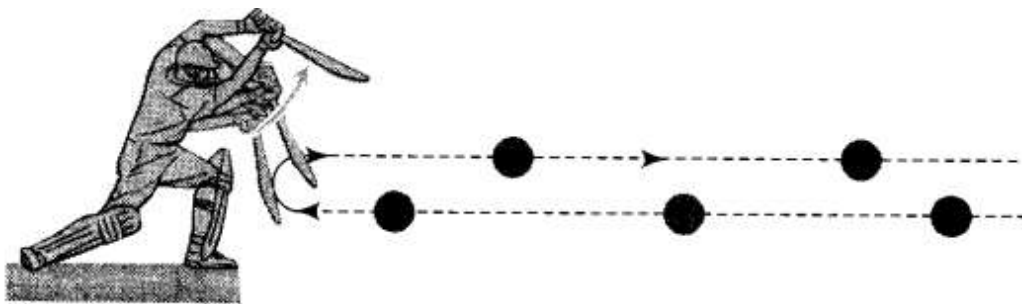

The variation of acceleration with time is shown in the graph.

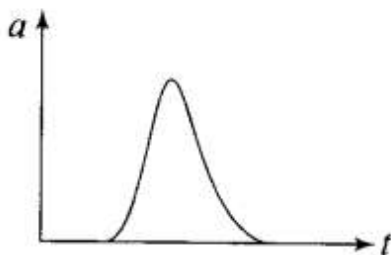

**Q14. Give examples of a one-dimensional motion where**

**(a) the particle moving along positive  $x$ -direction comes to rest periodically and moves forward.**

**(b) the particle moving along positive  $x$ -direction comes to rest periodically and moves backward.**

**Sol:** The equation which contains sine and cosine functions is periodic in nature.

(a) The particle will be moving along positive  $x$ -direction only if  $t > \sin t$  We have displacement as a function

of time,  $x(t) = t - \sin t$  By differentiating this equation w.r.t. time we get velocity of the particle as a function of time.

$$\text{velocity } v(t) = \frac{dx(t)}{dt} = 1 - \cos t$$

If we again differentiate this equation w.r.t. time we will get acceleration of the particle as a function of time.

$$\text{acceleration } a(t) = \frac{dv}{dt} = \sin t$$

$$\text{when } t = 0; x(t) = 0$$

$$\text{when } t = \pi; x(t) = \pi > 0$$

$$\text{when } t = 2\pi; x(t) = 2\pi > 0$$

(b) Equation can be represented by

$$x(t) = \sin t$$

$$v = \frac{d}{dt} x(t) = \cos t \text{ and } a = \frac{dv}{dt} = -\sin t$$

$$\text{At } t = 0; x = 0, v = 1 \text{ (positive) and } a = 0$$

$$\text{At } t = \frac{\pi}{2}; x = 1 \text{ (positive), } v = 0 \text{ and } a = -1 \text{ (negative)}$$

$$\text{At } t = \pi; x = 0, v = -1 \text{ (negative) and } a = 0$$

$$\text{At } t = \frac{3\pi}{2}; x = -1 \text{ (negative), } v = 0 \text{ and } a = +1 \text{ (positive)}$$

$$\text{At } t = 2\pi, x = 0, v = 1 \text{ (positive) and } a = 0$$

Hence the particle moving along positive x-direction comes to rest periodically and moves backward.

As displacement and velocity is involving  $\sin t$  and  $\cos t$ , hence these equations represent periodic nature.

**Q15. Give example of a motion where  $x > 0$ ,  $v < 0$ ,  $a > 0$  at a particular instant.**

**Sol:** Let the motion is represented by

$$x(t) = A + Be^{-\gamma t}$$

Let  $A > B$  and  $\gamma > 0$  ...(i)

Now velocity  $v(t) = \frac{dx}{dt} = -B\gamma e^{-\gamma t}$

Acceleration  $a(t) = \frac{dv}{dt} = B\gamma^2 e^{-\gamma t}$

Suppose we are considering any instant of time  $t$ , then from Eq. (i), we can say that

$$x(t) > 0; v(t) < 0 \text{ and } a > 0$$

**Q16. An object falling through a fluid is observed to have acceleration given by  $a = g - bv$  where  $g =$  gravitational acceleration and  $b$  is constant. After a long time of release, it is observed to fall with constant speed. What must be the value of the constant speed?**

**Sol:** Key concept: If a spherical body of radius  $r$  is dropped in a viscous fluid, it is first accelerated and then its acceleration becomes zero and it attains a constant velocity called terminal velocity.

According to the problem, acceleration of object is given by the relation

$$a = g - bv$$

When speed becomes constant acceleration  $a = dv/dt = 0$  (uniform motion).

where,  $g =$  gravitational acceleration

Clearly, from above equation as speed increases acceleration will decrease. At a certain speed say  $v_0$ , acceleration will be zero and speed will remain constant. Hence,  $a = g - bv_0 = 0 \Rightarrow v_0 = g/b$

### Short Answer Type Questions

**Q17. A ball is dropped and its displacement versus time graph is as shown (Displacement  $x$  from ground and all quantities are positive upwards).**

**(a) Plot qualitatively velocity versus time graph.**

**(b) Plot qualitatively acceleration versus time graph.**

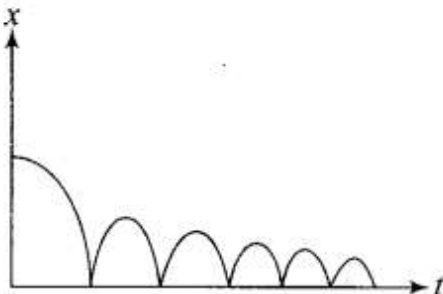

**Sol. Key concept:** To calculate velocity we will find slope which is calculated by  $\frac{dx}{dt}$  for displacement-time curve and to find acceleration we will find slope  $\frac{dV}{dt}$  of velocity-time curve.

**Sign convention:** We are taking downward as negative and upward as positive.

Ball is bouncing on the ground and it is clear from the graph that displacement  $x$  is positive throughout. Ball is dropped from a height and its velocity increases in downward direction due to gravity pull. In this condition  $v$  is negative but acceleration of the ball is equal to acceleration due to gravity *i.e.*,  $a = -g$ . When ball rebounds in upward direction its velocity is positive but acceleration is  $a = -g$ .

(a) The velocity-time graph of the ball is shown in fig. (i).

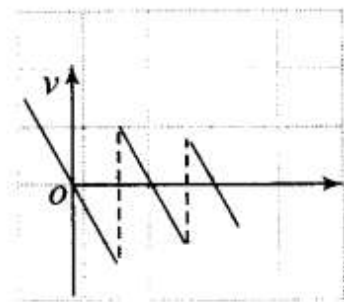

**Fig. (i)**

(b) The acceleration-time graph of the ball is shown in fig. (ii).

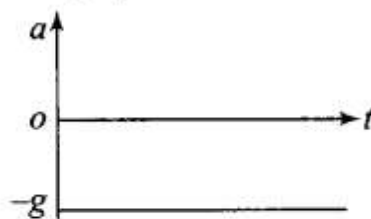

**Fig. (ii)**

18. A particle executes the motion described by  $x(t) = x_0(1 - e^{-\gamma t})$ ;  $t \geq 0$ ,  $x_0 > 0$ .
- Where does the particle start and with what velocity?
  - Find maximum and minimum values of  $x(t)$ ,  $v(t)$  and  $a(t)$ . Show that  $x(t)$  and  $a(t)$  increase with time and  $v(t)$  decreases with time.

**Sol.** Initially, we have to calculate velocity and acceleration and then we can determine the maximum or minimum value accordingly.

We have displacement as a function of time,

$$x(t) = x_0(1 - e^{-\gamma t})$$

By differentiating this equation w.r.t. time we get velocity of the particle as a function of time.

$$v(t) = \frac{dx(t)}{dt} = x_0\gamma e^{-\gamma t}$$

If we again differentiate this equation w.r.t. time we will get acceleration of the particle as a function of time.

$$a(t) = \frac{dv(t)}{dt} = -x_0\gamma^2 e^{-\gamma t}$$

- (a) When  $t = 0$ ;  $x(t) = x_0(1 - e^{-\gamma \cdot 0}) = x_0(1 - 1) = 0$

$$v(t=0) = x_0\gamma e^{-\gamma \cdot 0} = x_0\gamma(1) = \gamma x_0$$

- (b)  $x(t)$  is maximum when  $t = \infty$   $[x(t)]_{\max} = x_0$

$$x(t) \text{ is minimum when } t = 0 \quad [x(t)]_{\min} = 0$$

$$v(t) \text{ is maximum when } t = 0; \quad v(0) = x_0\gamma$$

$$v(t) \text{ is minimum when } t = \infty; \quad v(\infty) = 0$$

$$a(t) \text{ is maximum when } t = \infty; \quad a(\infty) = 0$$

$$a(t) \text{ is minimum when } t = 0; \quad a(0) = -x_0\gamma^2$$

Q19. A bird is tossing (flying to and fro) between two cars moving towards each other on a straight road. One car has a speed of 18 km/h while the other has the speed of 27 km/h. The bird starts moving from first car towards the other and is moving with the speed of 36 km/h and when the two cars were separated by 36 km. What is the total distance covered by the bird?

**Sol:**

Concept of relative velocity (for 1-D): If two objects are moving along the same straight line and we are observing the motion from the frame of one object. Then for the relative velocity, it will be subtracted for velocities in same direction and added for velocities in opposite directions. (Remember: add or subtract them with proper sign conventions).

In this problem we have to use the concept of relative velocity.

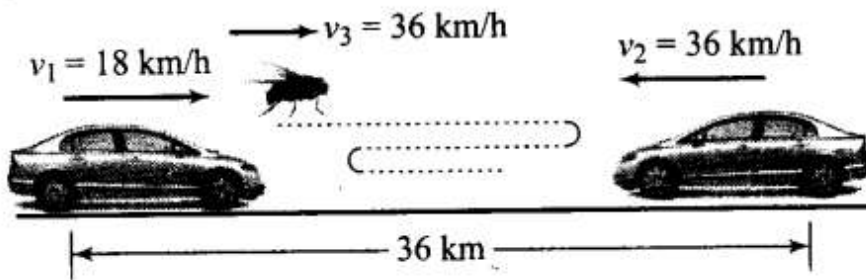

According to the problem, Speed of first car =  $18 \text{ km/h}$

Speed of second car =  $27 \text{ km/h}$

$\therefore$  Relative speed of each car w.r.t. each other

$$= 18 + 27 = 45 \text{ km/h}$$

Distance between the cars =  $36 \text{ km}$

$\therefore$  Time of meeting the cars ( $t$ )

$$= \frac{\text{Distance between the cars}}{\text{Relative speed of cars}}$$

$$= \frac{36}{45} = \frac{4}{5} \text{ h} = 0.8 \text{ h}$$

Speed of the bird ( $v_b$ ) =  $36 \text{ km/h}$

Distance covered by the bird

$$= v_b \times t = 36 \times 0.8 = 28.8 \text{ km}$$

**Q20.** A man runs across the roof-top of a tall building and jumps horizontally with the hope of landing on the roof of the next building which is at a lower height than the first. If his speed is  $9 \text{ m/s}$ , the (horizontal) distance between the two buildings is  $10 \text{ m}$  and the height difference is  $9 \text{ m}$ , will he be able to land on the next building? (Take  $g = 10 \text{ m/s}^2$ )

**Sol:** Key concept: Horizontal Projectile:

When a body is projected horizontally from a certain height 'y' vertically above the ground with initial velocity  $u$ . If friction is considered to be absent, then there is no other horizontal force which can affect the horizontal motion. The horizontal velocity therefore remains constant and so the object covers equal distance in horizontal direction in equal intervals of time.

Time of flight: If a body is projected horizontally from a height  $h$  with velocity  $u$  and time taken by the body to reach the ground is  $T$ , then

$$h = 0 + \frac{1}{2}gT^2 \quad (\text{for vertical motion})$$

$$T = \sqrt{\frac{2h}{g}}$$

Horizontal range: Let R be the horizontal distance travelled by the body

$$R = uT + \frac{1}{2}0T^2 \quad (\text{for horizontal motion } a = 0)$$

$$R = u\sqrt{\frac{2h}{g}}$$

We will apply kinematic one by one along downward and along horizontal. We first consider motion along horizontal and there is no horizontal force which can affect the horizontal motion. The horizontal velocity therefore remains constant and so the object covers equal distance in horizontal direction in equal intervals of time.

According to the problem, horizontal speed of the man ( $u_x$ ) = 9 m/s Horizontal distance between the two buildings = 10 m

Height difference between the two buildings = 9 m and  $g = 10 \text{ m/s}^2$

and  $g = 10 \text{ m/s}^2$

Let the man jump from point A and land on the roof of the next building at point B.

Taking motion in vertical direction,

$$y = ut + \frac{1}{2}at^2$$

$$9 = 0 \times t + \frac{1}{2} \times 10 \times t^2$$

$$9 = 5t^2$$

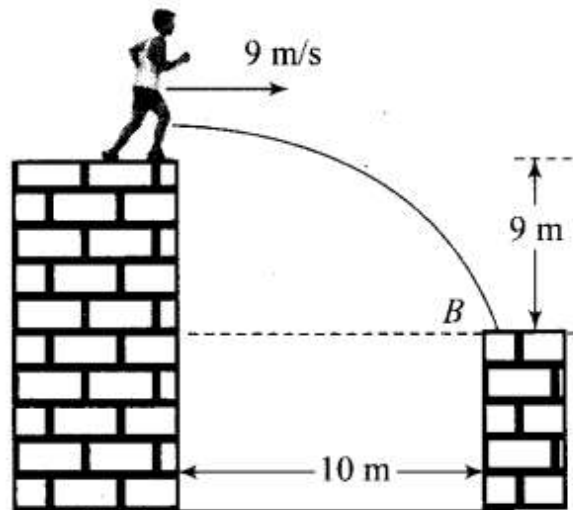

or  $t = \sqrt{\frac{9}{5}} = \frac{3}{\sqrt{5}}$

∴ Horizontal distance travelled

$$= u_x \times t = 9 \times \frac{3}{\sqrt{5}} = \frac{27}{\sqrt{5}} \text{ m} \approx 12 \text{ m}$$



Horizontal distance travelled by the man is greater than 10 m, therefore, he will land on the next building.

**Q21. A ball is dropped from a building of height 45 m. Simultaneously another ball is thrown up with a speed of 40 m/s. Calculate the relative speed of the balls as a function of time.**

**Sol:** In motion under gravity, if the ball is released or dropped that means its initial velocity is zero. In this problem as ball is dropped, so its initial velocity will be taken as zero. We will apply kinematic equations.

According to the problem, for the ball dropped from the building,  $u_1 = 0$ ,

$$u_2 = 40 \text{ m/s}$$

Velocity of the ball after time  $t$ ,

$$v_1 = u_1 - gt$$

$$v_1 = -gt$$

And for another ball which is thrown upward,

$$u_2 = 40 \text{ m/s}$$

Velocity of the ball after time  $t$ ,

$$v_2 = u_2 - gt = (40 - gt)$$

∴ Relative velocity of one ball w.r.t. another ball is

$$v_{12} = v_1 - v_2 = -gt - [-40 - gt]$$

$$v_{12} = v_1 - v_2 = -gt + 40 + gt = 40 \text{ m/s}$$

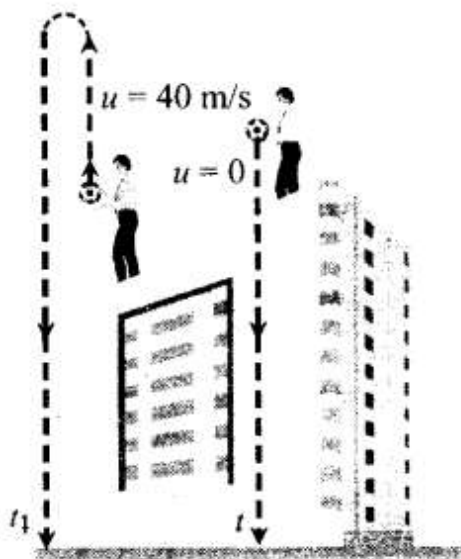

**Important point:** Sign Convention:

Any vector quantity directed upward will be taken as positive and directed downward will be taken as negative. According to this sign convention:

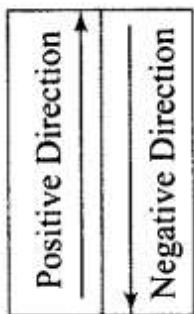

(i) Displacement will be taken as positive if final position lies above initial position and negative if final position lies below initial position.

(ii) Velocity(initial or final) will be taken as positive if it is upward and negative if it is downward.

(iii) Acceleration  $a$  is always taken to be  $-g$ .

In equations of motions we replace  $a$  by  $-g$  (minus sign, because acceleration is always directed downward)

we get: 
$$\begin{cases} v = u - gt \\ s = ut - \frac{1}{2}gt^2 \\ v^2 = u^2 - 2gs \end{cases}$$

Q22. The velocity-displacement graph of a particle is shown in figure.

(a) Write the relation between  $v$  and  $x$ .

(b) Obtain the relation between acceleration and displacement and plot it.

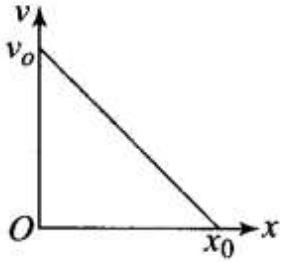

**Sol.** In this problem, we will use equation of straight line graph (linear equation).  $y = mx + c$ .

In this equation,  $m$  is the slope of the graph and  $c$  is the interception on  $y$ -axis.

Now according to the problem, initial velocity =  $v_0$

Let the distance travelled in time  $t = x_0$ .

$$\text{For the graph } \tan \theta = \frac{v_0}{x_0} = \frac{v_0 - v}{x} \quad \dots(i)$$

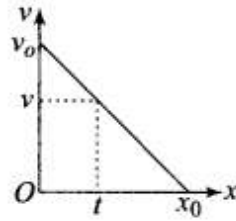

where,  $v$  is velocity and  $x$  is displacement at any instant of time  $t$ .

$$\text{From Eq. (i), } v_0 - v = \frac{v_0}{x_0} x$$

$$\Rightarrow v = \frac{-v_0}{x_0} x + v_0$$

We know that

$$\text{Acceleration } a = \frac{dv}{dt} = \frac{-v_0}{x_0} \frac{dx}{dt} + 0$$

$$\Rightarrow a = \frac{-v_0}{x_0} (v)$$

$$= \frac{-v_0}{x_0} \left( \frac{-v_0}{x_0} x + v_0 \right) = \frac{v_0^2}{x_0^2} x - \frac{v_0^2}{x_0}$$

**Graph of  $a$  versus  $x$  is given below.**

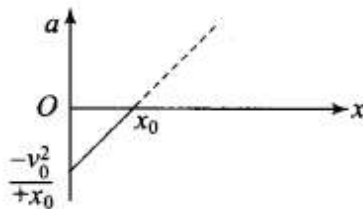

### Long Answer Type Questions

**Q23.** It is a common observation that rain clouds can be at about a kilometer altitude above the ground.

- If a rain drop falls from such a height freely under gravity, what will be its speed? Also calculate in km/h ( $g = 10 \text{ m/s}^2$ ).
- A typical rain drop is about 4 mm diameter. Momentum is mass  $\times$  speed in magnitude. Estimate its momentum when it hits the ground.
- Estimate the time required to flatten the drop.
- Rate of change of momentum's force. Estimate how much force such a drop would exert on you.
- Estimate the order of magnitude force on umbrella. Typical lateral separation between two rain drops is 5 cm. (Assume that umbrella is circular and has a diameter of 1 m and cloth is not pierced through)

**Sol:** Key concept: This problem can be solved by kinematic equations of motion and Newton's second law that  $F_{\text{ext}} = dp/dt$  will be used, where  $dp$  is change in momentum over time  $dt$ .

(a) According to the problem  $(h) = 1 \text{ km} = 1000 \text{ m}$  and we know that the initial velocity of the ball is zero. And displacement covered by rain drop in downward direction, so we will taking  $h$  as negative. (We are neglecting the air resistance.)

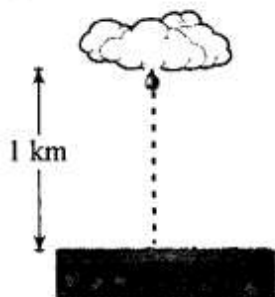

Velocity attained by the rain drop in freely falling through a height  $h$  is

$$v^2 = u^2 - 2g(-h)$$

As  $u = 0$

So,

$$v = \sqrt{2gh} = \sqrt{2 \times 10 \times 1000} = 100\sqrt{2} \text{ m/s}$$

$$= 100\sqrt{2} \times \frac{60 \times 60}{1000} \text{ km/h} = 360\sqrt{2} \text{ km/h} \approx 510 \text{ km/h}$$

(b) Diameter of the drop  $(d) = 2r = 4 \text{ mm}$

Radius of the drop  $(r) = 2 \text{ mm} = 2 \times 10^{-3} \text{ m}$

Mass of a rain drop  $(m) = V \times \rho$

$$= \frac{4}{3} \pi r^3 \rho = \frac{4}{3} \times \frac{22}{7} \times (2 \times 10^{-3})^3 \times 10^3$$

( $\because$  Density of water  $= 10^3 \text{ kg/m}^3$ )

$$\Rightarrow m = 3.4 \times 10^{-5} \text{ kg}$$

Momentum of the rain drop  $(p) = mv$

$$= 3.4 \times 10^{-5} \times 100\sqrt{2}$$

$$\Rightarrow p = 4.7 \times 10^{-3} \text{ kg-m/s} \approx 5 \times 10^{-3} \text{ kg-m/s}$$

(c) Time required to flatten the drop = Time taken by the drop to travel the distance equal to the diameter of the drop near the ground

$$t = \frac{d}{v} = \frac{4 \times 10^{-3}}{100\sqrt{2}} = 0.028 \times 10^{-3} \text{ s}$$

$$= 2.8 \times 10^{-5} \text{ s} \approx 30 \text{ ms}$$

(d) Force exerted by a rain drop is

$$F = \frac{\text{Change in momentum}}{\text{Time}} = \frac{p - 0}{t}$$

$$= \frac{4.7 \times 10^{-3}}{2.8 \times 10^{-5}} \approx 168 \text{ N}$$

(e) Radius of the umbrella ( $R$ ) =  $\frac{1}{2}$  m

$\therefore$  Area of the umbrella

$$(A) = \pi R^2 = \frac{22}{7} \times \left(\frac{1}{2}\right)^2$$

$$= \frac{22}{28} = \frac{11}{14} \approx 0.8 \text{ m}^2$$

Number of drops striking the umbrella simultaneously with average separation of 5 cm ( $5 \times 10^{-2}$  m)

$$n = \frac{0.8}{(5 \times 10^{-2})^2} = 320$$

$\therefore$  Net force exerted on umbrella =  $320 \times 168 = 53760 \text{ N} \approx 54000 \text{ N}$

**Q24.** A motor car moving at a speed of 72 km/h cannot come to a stop in less than 3.0 s while for a truck this time interval is 5.0 s. On a highway, the car is behind the truck both moving at 72 km/h. The truck gives a signal that it is going to stop at emergency. At what distance the car should be from the truck so that it does not bump onto (collide with) the truck. Human response time is 0.5 s.

**Sol:** According to the problem, speed of car as well as truck = 72 km/h

$$= 72 \times \frac{5}{18} \text{ m/s} = 20 \text{ m/s}$$



Time required to stop the truck = 5 s

Finally the truck comes to rest, so final velocity of truck will be zero.

Retardation produced by truck:

$$v = u + a_t t$$

$$0 = 20 + a_t \times 5$$

or  $a_t = -4 \text{ m/s}^2$

Time required to stop the car = 3 s

Finally the car comes to rest just behind the truck in the same time to avoid collision, so final velocity of car will also be zero.

Retardation produced by car is

$$v = u + a_c t$$

$$0 = 20 + a_c \times 3$$

or  $a_c = -\frac{20}{3} \text{ m/s}^2$

Let car be at a distance  $s$  from the truck, when truck gives the signal and  $t$  be the time taken to cover this distance.

As human response time is 0.5 s, in this time car will cover some distance with uniform velocity. Therefore, time of retarded motion of car is  $(t - 0.5)$  s. Velocity of car after time  $t$ ,

$$v_c = u - at = 20 - \left(\frac{20}{3}\right)(t - 0.5)$$

Velocity of truck after time  $t$ ,

$$v_t = 20 - 4t$$

To avoid the car bump onto the truck

$$20 - \frac{20}{3}(t - 0.5) = 20 - 4t$$

$$4t = \frac{20}{3}(t - 0.5)$$

$$\Rightarrow t = \frac{2.5}{2} = \frac{5}{4} \text{ s}$$

Distance travelled by the truck in time  $t$ ,

$$s_t = u_t t + \frac{1}{2} a_t t^2$$

$$\Rightarrow s_t = 20 \times \frac{5}{4} + \frac{1}{2} \times (-4) \times \left(\frac{5}{4}\right)^2 = 21.875 \text{ m}$$

Distance travelled by car in time  $t =$  Distance travelled by car in 0.5 s (without retardation) + Distance travelled by car in  $(t - 0.5)$  s (with retardation)

$$s_c = (20 \times 0.5) + 20\left(\frac{5}{4} - 0.5\right) - \frac{1}{2}\left(\frac{20}{3}\right)\left(\frac{5}{4} - 0.5\right)^2 = 23.125 \text{ m}$$

$$\therefore s_c - s_t = 23.125 - 21.875 = 1.250 \text{ m}$$

Therefore, to avoid the collision with the truck, the car must maintain a distance from the truck more than 1.250 m.

Q25. A monkey climbs up a slippery pole for 3 and subsequently slips for 3 seconds. Its velocity at time  $t$  is given by  $v(t) = 2t(3 - t)$ ;  $0 < t < 3$  and  $v(t) = -(t - 3)(6 - t)$  for  $3 < t < 6$  s in m/s. It repeats this cycle till it reaches the height of 20 m.

(a) At what time is its velocity maximum?

(b) At what time is its average velocity maximum?

(c) At what time is its acceleration maximum in magnitude?

(d) How many cycles (counting fractions) are required to reach the top? Sol. We have to calculate time corresponding to maximum velocity. So we first need to find the maximum velocity in this problem. To calculate maximum  $dv$  velocity we will use  $dv/dt=0$

Given velocity

$$v(t) = 2t(3 - t) = 6t - 2t^2 \quad \dots(i)$$

(a) For maximum velocity  $\frac{dv(t)}{dt} = 0$

$$\Rightarrow \frac{d}{dt}(6t - 2t^2) = 0$$

$$\Rightarrow 6 - 4t = 0$$

$$\Rightarrow t = \frac{6}{4} = \frac{3}{2} \text{ s} = 1.5 \text{ s}$$

(b) From Eq. (i)  $v = 6t - 2t^2$

$$\Rightarrow \frac{ds}{dt} = 6t - 2t^2$$

$$\Rightarrow ds = (6t - 2t^2)dt$$

where,  $s$  is displacement

$\therefore$  Distance travelled in time interval 0 to 3 s,

$$\begin{aligned} s &= \int_0^3 (6t - 2t^2) dt \\ &= \left[ \frac{6t^2}{2} - \frac{2t^3}{3} \right]_0^3 = \left[ 3t^2 - \frac{2}{3}t^3 \right]_0^3 \end{aligned}$$



$$\begin{aligned} &= 3 \times 9 - \frac{2}{3} \times 3 \times 3 \times 3 \\ &= 27 - 18 = 9 \text{ m} \end{aligned}$$

$$\begin{aligned} \text{Average velocity} &= \frac{\text{Distance travelled}}{\text{Time}} \\ &= \frac{9}{3} = 3 \text{ m/s} \end{aligned}$$

$$\text{Given, } x = 6t - 2t^2$$

$$\Rightarrow 3 = 6t - 2t^2 \Rightarrow 2t^2 - 6t - 3 = 0$$

$$\begin{aligned} \Rightarrow t &= \frac{6 \pm \sqrt{6^2 - 4 \times 2 \times 3}}{2 \times 2} = \frac{6 \pm \sqrt{36 - 24}}{4} \\ &= \frac{6 \pm \sqrt{12}}{4} = \frac{3 \pm 2\sqrt{3}}{2} \end{aligned}$$

Considering positive sign only

$$t = \frac{3 + 2\sqrt{3}}{2} = \frac{3 + 2 \times 1.732}{2} = \frac{9}{4} \text{ s}$$

(c) In a periodic motion when velocity is zero acceleration will be maximum putting  $v = 0$  in Eq. (i).

$$0 = 6t - 2t^2 \Rightarrow 0 = t(6 - 2t)$$

$$= t \times 2(3 - t) = 0 \Rightarrow t = 0 \text{ or } 3 \text{ s}$$

(d) Distance covered in 0 to 3 s = 9 m

Distance covered in 3 to 6 s

$$= \int_3^6 (18 - 9t + t^2) dt = \left( 18t - \frac{9t^2}{2} + \frac{t^3}{3} \right)_3^6$$

$$= 18 \times 6 - \frac{9}{2} \times 6^2 + \frac{6^3}{3} - \left( 18 \times 3 - \frac{9 \times 3^2}{2} + \frac{3^3}{3} \right)$$

$$= 108 - 9 \times 18 + \frac{6^3}{3} - 18 \times 3 + \frac{9}{2} \times 9 - \frac{27}{3}$$

$$= -4.5 \text{ m}$$

$\therefore$  Total distance travelled in one cycle

$$= s_1 + s_2 = 9 - 4.5 = 4.5 \text{ m}$$

$$\text{Number of cycles to be covered in total distance} = \frac{20}{4.5} \approx 4.44 \approx 5$$

**Q26.** A man is standing on top of a building 100 m high. He throws two balls vertically, one at  $t = 0$  and after a time interval (less than 2 seconds). The later ball is thrown at a velocity of half the first. The vertical gap between first and second ball is + 15 m at  $t = 2$  s. The gap is found to remain constant. Calculate the velocity with which the balls were thrown and the exact time interval between their throw.

**Sol:** We solve this problem by using kinematic equations with proper sign convention and to calculate time interval we will take We solve this problem by using kinematic equations with proper sign convention and to calculate time interval we will take difference of displacements.

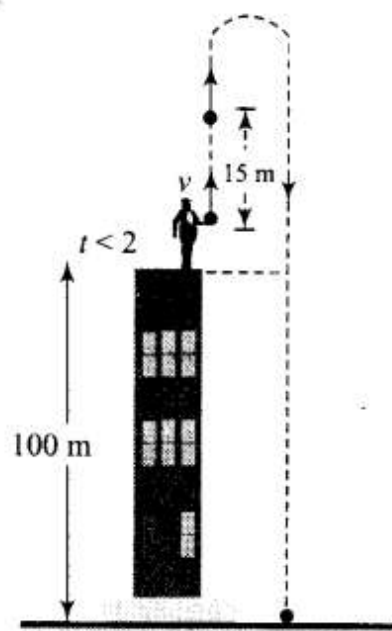
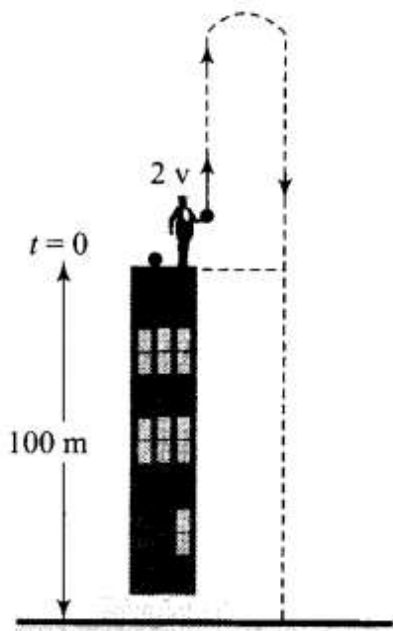

Let the speeds of the two balls (1 and 2) be  $v_1$  and  $v_2$  where:

if  $v_1 = 2v$ ,  $v_2 = v$

if  $y_1$  and  $y_2$  and the displacement covered by the balls 1 and 2, respectively, before coming to rest, then

$$y_1 = \frac{v_1^2}{2g} = \frac{4v^2}{2g} \text{ and } y_2 = \frac{v_2^2}{2g} = \frac{v^2}{2g}$$

$$\begin{aligned} \text{Since } y_1 - y_2 &= 15 \text{ m, } \frac{4v^2}{2g} - \frac{v^2}{2g} \\ &= 15 \text{ m or } \frac{3v^2}{2g} = 15 \text{ m} \end{aligned}$$

$$\text{or } v^2 = \sqrt{5 \text{ m} \times (2 \times 10) \text{ m/s}^2}$$

$$\text{or } v = 10 \text{ m/s}$$

Clearly,  $v_1 = 20 \text{ m/s}$  and  $v_2 = 10 \text{ m/s}$

$$\text{as } y_1 = \frac{v_1^2}{2g} = \frac{(20 \text{ m})^2}{2 \times 10 \text{ m}} = 20 \text{ m}$$

$$y_2 = y_1 - 15 \text{ m} = 5 \text{ m}$$

If  $t_2$  is the time taken by the ball 2 to cover a displacement of 5 m, then from

$$y_2 = v_2 t - \frac{1}{2} g t_2^2$$

$$5 = 10 t_2 - 5 t_2^2 \text{ or } t_2^2 - 2 t_2 + 1 = 0$$

$$\text{where } t_2 = 1 \text{ s}$$

Since  $t_1$  (time taken by ball 1 to cover distance of 20 m) is 2 s, time interval between the two throws

$$= t_1 - t_2 = 2 \text{ s} - 1 \text{ s} = 1 \text{ s}$$

Important note: We should be very careful when we are applying the equation of rectilinear motion. These equations are applicable only in case of constant acceleration.

Some important observations for motion under gravity:

- The motion is independent of the mass of the body, as in any equation of motion, mass is not involved. That is why a heavy and light body when released from the same height, reach the ground simultaneously and with same velocity, i.e.,  $t = \sqrt{(2h/g)}$  and  $v = \sqrt{2gh}$ .
- In case of motion under gravity time taken to go up is equal to the time taken to fall down through the same distance.

Time of descent ( $t_1$ ) = time of ascent ( $t_2$ ) =  $u/g$

Total time of flight  $T = t_1 + t_2 = .2u / g$

- In case of motion under gravity, the speed with which a body is projected up is equal to the speed with which it comes back to the point of projection.  
As well as the magnitude of velocity at any point on the path is same whether the body is moving in upwards or downward direction.
- A body is thrown vertically upwards. If air resistance is to be taken into account, then the time of ascent is less than the time of descent  $t_2 > t_1$

Let  $u$  be the initial velocity of body, then time of ascent  $t_1 = \frac{u}{g+a}$   
and  $h = \frac{u^2}{2(g+a)}$

where  $g$  is acceleration due to gravity and  $a$  is retardation by air resistance and for upward motion both will act vertically downward.

For downward motion  $a$  and  $g$  will act in opposite direction because  $a$  always act in direction opposite to motion and  $g$  always act vertically downward.

$$\text{So } h = \frac{1}{2}(g-a)t_2^2$$

$$\Rightarrow \frac{u^2}{2(g+a)} = \frac{1}{2}(g-a)t_2^2$$

$$\Rightarrow t_2 = \frac{u}{\sqrt{(g+a)(g-a)}}$$

Comparing  $t_1$  and  $t_2$  we can say that  $t_2 > t_1$ ,  
since  $(g+a) > (g-a)$