

CHAPTER 13

ANSWERS

Multiple Choice Questions

1. (c) 2. (c) **Hint**— Only earth's magnetic field will be present.
3. (a) **Hint**— Misconception is that magnetic field lines point from north to south pole. The fact is that they emerge out of North pole and enter into South pole.
4. (c) 5. (a) 6. (c) 7. (d)
8. (d) AC frequency in India is 50 Hz. The direction changes twice in each cycle so that change of direction takes place after every $\frac{1}{100}$ second.
9. (b) 10. (c) 11. (a) 12. (b)

Short Answer Questions

13. In the plane of the paper itself. The axis of the compass is vertical and the field due to the conductor is also vertical. It could result in a dip of compass needle which is not possible in this case (dips result only if axis of compass is horizontal). The deflection is maximum when the conductor through A is perpendicular to the plane of paper and the field due to it is maximum in the plane of the paper.
14. **Hint**— (i) The current through the solenoid should be direct current.
(ii) The rod inside is made of a magnetic material such as steel.
15. **Into** the plane of paper at P and **out** of it at Q. The strength of the magnetic field is larger at the point located closer i.e. at Q.
16. The deflection increases. The strength of magnetic field is directly proportional to the magnitude of current passing through the straight conductor.
17. **Hint**— (i) Yes, Alpha particles being positively charged constitutes a current in the direction of motion. (ii) No. The neutrons being electrically neutral constitute no current.

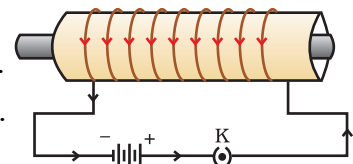

18. The thumb indicates the direction of current in the straight conductor held by curled fingers, whereas the Fleming's left-hand rule gives the direction of force experienced by current carrying conductor placed in an external magnetic field.
19. Strength of the magnetic field falls as distance increases. This is indicated by the decrease in degree of closeness of the lines of field.
20. The divergence, that is, the falling degree of closeness of magnetic field lines indicates the fall in strength of magnetic field near and beyond the ends of the solenoid.
21. Electric fans, mixers, washing machines, computer drives, etc. Motors convert electrical energy into mechanical energy whereas generators convert mechanical energy into electrical energy.
22. The brushes are connected to the battery and touch the outer side of two halves of the split ring whose inner sides are insulated and attached to the axle.
23. Direct current always flows in one direction but the alternating current reverses its direction periodically. The frequency of AC in India is 50 Hz and in each cycle it alters direction twice. Therefore AC changes direction $2 \times 50 = 100$ times in one second.
24. Fuse is used for protecting appliances due to short-circuiting or overloading. The fuse is rated for a certain maximum current and blows off when a current more than the rated value flows through it. If a fuse is replaced by one with larger ratings, the appliances may get damaged while the protecting fuse does not burn off. This practice of using fuse of improper rating should always be avoided.

Long Answer Questions

25. Current carrying loops behave like bar magnets and both have their associated lines of field. This modifies the already existing earth's magnetic field and a deflection results. Magnetic field has both direction and magnitude. Magnetic field lines emerge from N-pole and enter S-pole. The magnetic field strength is represented diagrammatically by the degree of closeness of the field lines. Field lines cannot cross each other as two values of net field at a single point cannot exist.

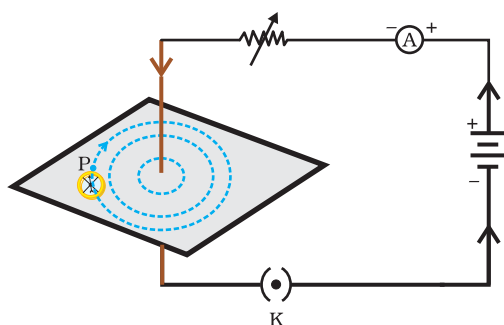

Only one value, a unique net value, can exist. If in a given region, lines of field are shown to be parallel and equispaced, the field is understood to be uniform.

26. Right hand thumb rule states that if a current carrying straight conductor is supposedly held in the right hand with the thumb pointing towards the direction of current, then the fingers will wrap around the conductor in the direction of the field lines of the magnetic field.

27. Hint— The magnetic field at a point is the addition of the field produced by each turn.

28. Hint— Explain the activity with the help of the diagram. According to Fleming's left hand rule, stretch the thumb, forefinger and central finger of your left hand such that they are mutually perpendicular. If the fore finger points in the direction of magnetic field and the central in the direction of current, then the thumb will point in the direction of motion or force acting on the conductor.

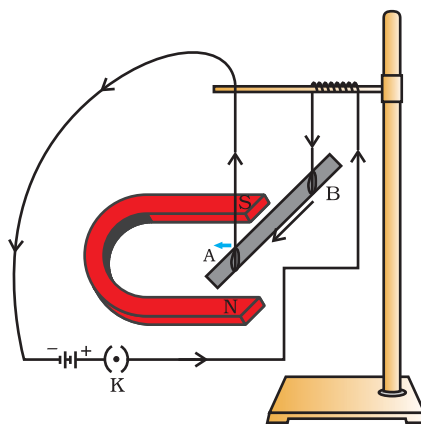
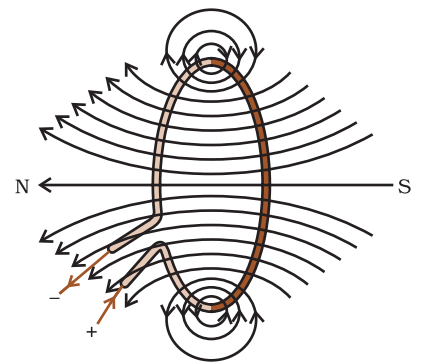

29. Hint— Explain working with the help of the diagram. Commercial motors use an electromagnet in place of a permanent magnet, a large number of turns of conducting wire in the current carrying coil and a soft iron core on which the coil is wound.

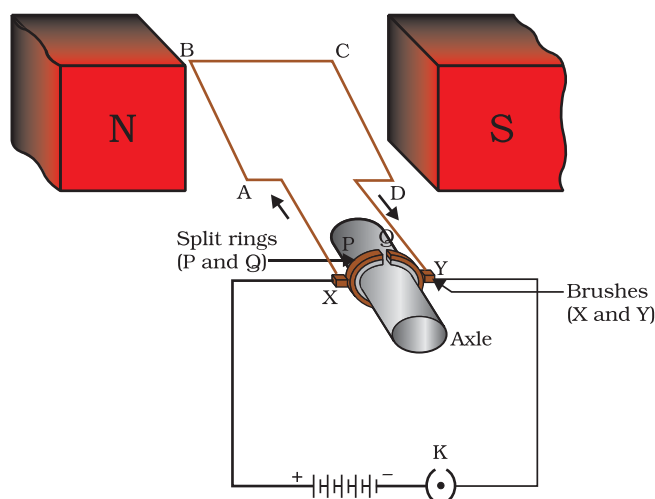

- 30. Hint—** The process by which a changing magnetic field in a conductor induces a current in another conductor is called electromagnetic induction.

Explain the working of the set up with the help of the diagram.

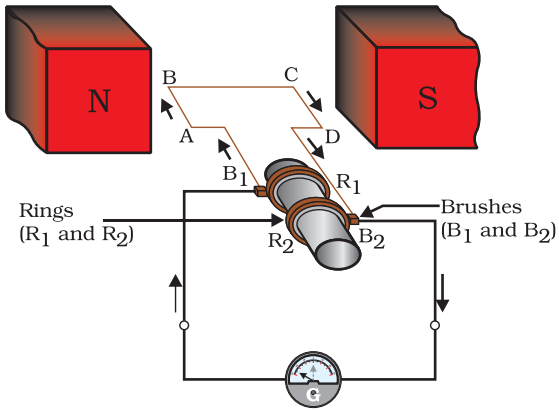
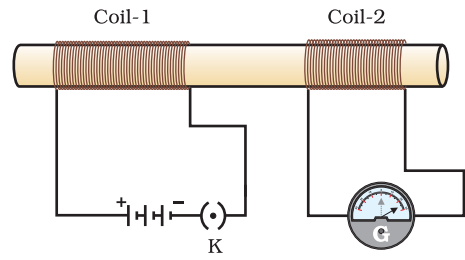

- 31.** Explain working with the help of the diagram. To get a direct current a split ring type commutator must be used in place of slip ring type commutator.

- 32. Hint—**

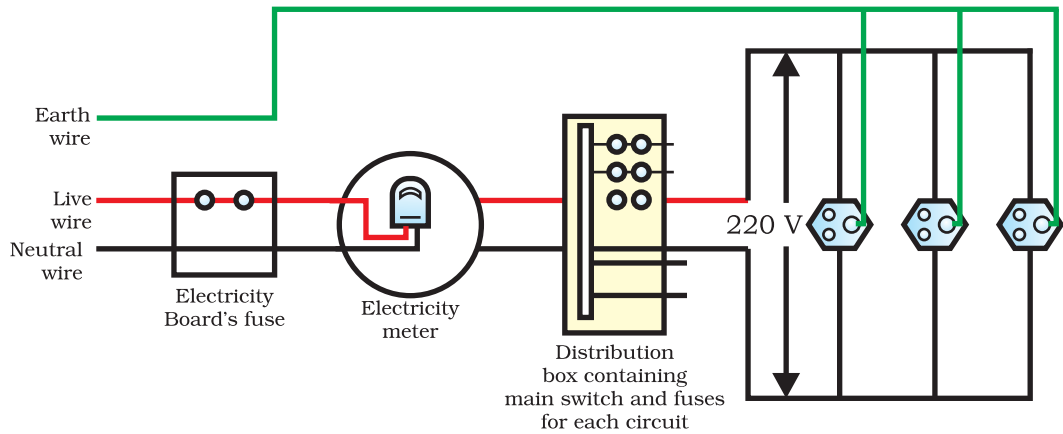

A fuse in a circuit prevents damage to the appliances and the circuit due to overloading. Otherwise the appliances or the circuit may get damaged.