

Chapter 11 – Conic Sections

Page No 241:

Question 1:

Find the equation of the circle with centre (0, 2) and radius 2

Answer:

The equation of a circle with centre (h, k) and radius r is given as

$$(x - h)^2 + (y - k)^2 = r^2$$

It is given that centre (h, k) = (0, 2) and radius (r) = 2.

Therefore, the equation of the circle is

$$(x - 0)^2 + (y - 2)^2 = 2^2$$

$$x^2 + y^2 + 4 - 4y = 4$$

$$x^2 + y^2 - 4y = 0$$

Question 2:

Find the equation of the circle with centre (-2, 3) and radius 4

Answer:

The equation of a circle with centre (h, k) and radius r is given as

$$(x - h)^2 + (y - k)^2 = r^2$$

It is given that centre (h, k) = (-2, 3) and radius (r) = 4.

Therefore, the equation of the circle is

$$(x + 2)^2 + (y - 3)^2 = (4)^2$$

$$x^2 + 4x + 4 + y^2 - 6y + 9 = 16$$

$$x^2 + y^2 + 4x - 6y - 3 = 0$$

Question 3:

Find the equation of the circle with centre $\left(\frac{1}{2}, \frac{1}{4}\right)$ and radius $\frac{1}{12}$

Answer:

The equation of a circle with centre (h, k) and radius r is given as

$$(x - h)^2 + (y - k)^2 = r^2$$

It is given that centre (h, k) = $\left(\frac{1}{2}, \frac{1}{4}\right)$ and radius (r) = $\frac{1}{12}$.

Therefore, the equation of the circle is

$$\left(x - \frac{1}{2}\right)^2 + \left(y - \frac{1}{4}\right)^2 = \left(\frac{1}{12}\right)^2$$

$$x^2 - x + \frac{1}{4} + y^2 - \frac{y}{2} + \frac{1}{16} = \frac{1}{144}$$

$$x^2 - x + \frac{1}{4} + y^2 - \frac{y}{2} + \frac{1}{16} - \frac{1}{144} = 0$$

$$144x^2 - 144x + 36 + 144y^2 - 72y + 9 - 1 = 0$$

$$144x^2 - 144x + 144y^2 - 72y + 44 = 0$$

$$36x^2 - 36x + 36y^2 - 18y + 11 = 0$$

$$36x^2 + 36y^2 - 36x - 18y + 11 = 0$$

Question 4:

Find the equation of the circle with centre (1, 1) and radius $\sqrt{2}$

Answer:

The equation of a circle with centre (h, k) and radius r is given as

$$(x - h)^2 + (y - k)^2 = r^2$$

It is given that centre (h, k) = (1, 1) and radius (r) = $\sqrt{2}$.

Therefore, the equation of the circle is

$$(x - 1)^2 + (y - 1)^2 = (\sqrt{2})^2$$

$$x^2 - 2x + 1 + y^2 - 2y + 1 = 2$$

$$x^2 + y^2 - 2x - 2y = 0$$

Question 5:

Find the equation of the circle with centre (-a, -b) and radius $\sqrt{a^2 - b^2}$

Answer:

The equation of a circle with centre (h, k) and radius r is given as

$$(x - h)^2 + (y - k)^2 = r^2$$

It is given that centre $(h, k) = (-a, -b)$ and radius $(r) = \sqrt{a^2 - b^2}$.

Therefore, the equation of the circle is

$$\begin{aligned}(x + a)^2 + (y + b)^2 &= (\sqrt{a^2 - b^2})^2 \\ x^2 + 2ax + a^2 + y^2 + 2by + b^2 &= a^2 - b^2 \\ x^2 + y^2 + 2ax + 2by + 2b^2 &= 0\end{aligned}$$

Question 6:

Find the centre and radius of the circle $(x + 5)^2 + (y - 3)^2 = 36$

Answer:

The equation of the given circle is $(x + 5)^2 + (y - 3)^2 = 36$.

$$(x + 5)^2 + (y - 3)^2 = 36$$

$\Rightarrow \{x - (-5)\}^2 + (y - 3)^2 = 6^2$, which is of the form $(x - h)^2 + (y - k)^2 = r^2$, where $h = -5$, $k = 3$, and $r = 6$.

Thus, the centre of the given circle is $(-5, 3)$, while its radius is 6.

Question 7:

Find the centre and radius of the circle $x^2 + y^2 - 4x - 8y - 45 = 0$

Answer:

The equation of the given circle is $x^2 + y^2 - 4x - 8y - 45 = 0$.

$$x^2 + y^2 - 4x - 8y - 45 = 0$$

$$\Rightarrow (x^2 - 4x) + (y^2 - 8y) = 45$$

$$\Rightarrow \{x^2 - 2(x)(2) + 2^2\} + \{y^2 - 2(y)(4) + 4^2\} - 4 - 16 = 45$$

$$\Rightarrow (x - 2)^2 + (y - 4)^2 = 65$$

$\Rightarrow (x - 2)^2 + (y - 4)^2 = (\sqrt{65})^2$, which is of the form $(x - h)^2 + (y - k)^2 = r^2$, where $h = 2$, $k = 4$, and $r = \sqrt{65}$.

Thus, the centre of the given circle is $(2, 4)$, while its radius is $\sqrt{65}$.

Question 8:

Find the centre and radius of the circle $x^2 + y^2 - 8x + 10y - 12 = 0$

Answer:

The equation of the given circle is $x^2 + y^2 - 8x + 10y - 12 = 0$.

$$x^2 + y^2 - 8x + 10y - 12 = 0$$

$$\Rightarrow (x^2 - 8x) + (y^2 + 10y) = 12$$

$$\Rightarrow \{x^2 - 2(x)(4) + 4^2\} + \{y^2 + 2(y)(5) + 5^2\} - 16 - 25 = 12$$

$$\Rightarrow (x - 4)^2 + (y + 5)^2 = 53$$

$$\Rightarrow (x - 4)^2 + \{y - (-5)\}^2 = (\sqrt{53})^2, \text{ which is of the form } (x - h)^2 + (y - k)^2 = r^2, \text{ where } h = 4, k = -5, \text{ and } r = \sqrt{53}.$$

Thus, the centre of the given circle is $(4, -5)$, while its radius is $\sqrt{53}$.

Question 9:

Find the centre and radius of the circle $2x^2 + 2y^2 - x = 0$

Answer:

The equation of the given circle is $2x^2 + 2y^2 - x = 0$.

$$2x^2 + 2y^2 - x = 0$$

$$\Rightarrow (2x^2 - x) + 2y^2 = 0$$

$$\Rightarrow 2 \left[\left(x^2 - \frac{x}{2} \right) + y^2 \right] = 0$$

$$\Rightarrow \left\{ x^2 - 2 \cdot x \left(\frac{1}{4} \right) + \left(\frac{1}{4} \right)^2 \right\} + y^2 - \left(\frac{1}{4} \right)^2 = 0$$

$$\Rightarrow \left(x - \frac{1}{4} \right)^2 + (y - 0)^2 = \left(\frac{1}{4} \right)^2, \text{ which is of the form } (x - h)^2 + (y - k)^2 = r^2, \text{ where } h = \frac{1}{4}, k = 0,$$

and $r = \frac{1}{4}$.

Thus, the centre of the given circle is $\left(\frac{1}{4}, 0 \right)$, while its radius is $\frac{1}{4}$.

Question 10:

Find the equation of the circle passing through the points (4, 1) and (6, 5) and whose centre is on the line $4x + y = 16$.

Answer:

Let the equation of the required circle be $(x - h)^2 + (y - k)^2 = r^2$.

Since the circle passes through points (4, 1) and (6, 5),

$$(4 - h)^2 + (1 - k)^2 = r^2 \dots (1)$$

$$(6 - h)^2 + (5 - k)^2 = r^2 \dots (2)$$

Since the centre (h, k) of the circle lies on line $4x + y = 16$,

$$4h + k = 16 \dots (3)$$

From equations (1) and (2), we obtain

$$(4 - h)^2 + (1 - k)^2 = (6 - h)^2 + (5 - k)^2$$

$$\Rightarrow 16 - 8h + h^2 + 1 - 2k + k^2 = 36 - 12h + h^2 + 25 - 10k + k^2$$

$$\Rightarrow 16 - 8h + 1 - 2k = 36 - 12h + 25 - 10k$$

$$\Rightarrow 4h + 8k = 44$$

$$\Rightarrow h + 2k = 11 \dots (4)$$

On solving equations (3) and (4), we obtain $h = 3$ and $k = 4$.

On substituting the values of h and k in equation (1), we obtain

$$(4 - 3)^2 + (1 - 4)^2 = r^2$$

$$\Rightarrow (1)^2 + (-3)^2 = r^2$$

$$\Rightarrow 1 + 9 = r^2$$

$$\Rightarrow r^2 = 10$$

$$\Rightarrow r = \sqrt{10}$$

Thus, the equation of the required circle is

$$(x - 3)^2 + (y - 4)^2 = (\sqrt{10})^2$$

$$x^2 - 6x + 9 + y^2 - 8y + 16 = 10$$

$$x^2 + y^2 - 6x - 8y + 15 = 0$$

Question 11:

Find the equation of the circle passing through the points (2, 3) and (-1, 1) and whose centre is on the line $x - 3y - 11 = 0$.

Answer:

Let the equation of the required circle be $(x - h)^2 + (y - k)^2 = r^2$.

Since the circle passes through points (2, 3) and (-1, 1),

$$(2 - h)^2 + (3 - k)^2 = r^2 \dots (1)$$

$$(-1 - h)^2 + (1 - k)^2 = r^2 \dots (2)$$

Since the centre (h, k) of the circle lies on line $x - 3y - 11 = 0$,

$$h - 3k = 11 \dots (3)$$

From equations (1) and (2), we obtain

$$(2 - h)^2 + (3 - k)^2 = (-1 - h)^2 + (1 - k)^2$$

$$\Rightarrow 4 - 4h + h^2 + 9 - 6k + k^2 = 1 + 2h + h^2 + 1 - 2k + k^2$$

$$\Rightarrow 4 - 4h + 9 - 6k = 1 + 2h + 1 - 2k$$

$$\Rightarrow 6h + 4k = 11 \dots (4)$$

On solving equations (3) and (4), we obtain $h = \frac{7}{2}$ and $k = \frac{-5}{2}$.

On substituting the values of h and k in equation (1), we obtain

$$\begin{aligned} \left(2 - \frac{7}{2}\right)^2 + \left(3 + \frac{5}{2}\right)^2 &= r^2 \\ \Rightarrow \left(\frac{4-7}{2}\right)^2 + \left(\frac{6+5}{2}\right)^2 &= r^2 \\ \Rightarrow \left(\frac{-3}{2}\right)^2 + \left(\frac{11}{2}\right)^2 &= r^2 \\ \Rightarrow \frac{9}{4} + \frac{121}{4} &= r^2 \\ \Rightarrow \frac{130}{4} &= r^2 \end{aligned}$$

Thus, the equation of the required circle is

$$\left(x - \frac{7}{2}\right)^2 + \left(y + \frac{5}{2}\right)^2 = \frac{130}{4}$$

$$\left(\frac{2x-7}{2}\right)^2 + \left(\frac{2y+5}{2}\right)^2 = \frac{130}{4}$$

$$4x^2 - 28x + 49 + 4y^2 + 20y + 25 = 130$$

$$4x^2 + 4y^2 - 28x + 20y - 56 = 0$$

$$4(x^2 + y^2 - 7x + 5y - 14) = 0$$

$$x^2 + y^2 - 7x + 5y - 14 = 0$$

Question 12:

Find the equation of the circle with radius 5 whose centre lies on x-axis and passes through the point (2, 3).

Answer:

Let the equation of the required circle be $(x - h)^2 + (y - k)^2 = r^2$.

Since the radius of the circle is 5 and its centre lies on the x-axis, $k = 0$ and $r = 5$.

Now, the equation of the circle becomes $(x - h)^2 + y^2 = 25$.

It is given that the circle passes through point (2, 3).

$$\therefore (2 - h)^2 + 3^2 = 25$$

$$\Rightarrow (2 - h)^2 = 25 - 9$$

$$\Rightarrow (2 - h)^2 = 16$$

$$\Rightarrow 2 - h = \pm\sqrt{16} = \pm 4$$

If $2 - h = 4$, then $h = -2$.

If $2 - h = -4$, then $h = 6$.

When $h = -2$, the equation of the circle becomes

$$(x + 2)^2 + y^2 = 25$$

$$x^2 + 4x + 4 + y^2 = 25$$

$$x^2 + y^2 + 4x - 21 = 0$$

When $h = 6$, the equation of the circle becomes

$$(x - 6)^2 + y^2 = 25$$

$$x^2 - 12x + 36 + y^2 = 25$$

$$x^2 + y^2 - 12x + 11 = 0$$

Question 13:

Find the equation of the circle passing through (0, 0) and making intercepts a and b on the coordinate axes.

Answer:

Let the equation of the required circle be $(x - h)^2 + (y - k)^2 = r^2$.

Since the circle passes through (0, 0),

$$(0 - h)^2 + (0 - k)^2 = r^2$$

$$\therefore h^2 + k^2 = r^2$$

The equation of the circle now becomes $(x - h)^2 + (y - k)^2 = h^2 + k^2$.

It is given that the circle makes intercepts a and b on the coordinate axes. This means that the circle passes through points $(a, 0)$ and $(0, b)$. Therefore,

$$(a - h)^2 + (0 - k)^2 = h^2 + k^2 \quad (1)$$

$$(0 - h)^2 + (b - k)^2 = h^2 + k^2 \quad (2)$$

From equation (1), we obtain

$$a^2 - 2ah + h^2 + k^2 = h^2 + k^2$$

$$\therefore a^2 - 2ah = 0$$

$$\therefore a(a - 2h) = 0$$

$$\therefore a = 0 \text{ or } (a - 2h) = 0$$

However, $a \neq 0$; hence, $(a - 2h) = 0 \therefore h = \frac{a}{2}$.

From equation (2), we obtain

$$h^2 + b^2 - 2bk + k^2 = h^2 + k^2$$

$$\therefore b^2 - 2bk = 0$$

$$\therefore b(b - 2k) = 0$$

$$\therefore b = 0 \text{ or } (b - 2k) = 0$$

However, $b \neq 0$; hence, $(b - 2k) = 0 \therefore k = \frac{b}{2}$.

Thus, the equation of the required circle is

$$\begin{aligned} \left(x - \frac{a}{2}\right)^2 + \left(y - \frac{b}{2}\right)^2 &= \left(\frac{a}{2}\right)^2 + \left(\frac{b}{2}\right)^2 \\ \Rightarrow \left(\frac{2x-a}{2}\right)^2 + \left(\frac{2y-b}{2}\right)^2 &= \frac{a^2+b^2}{4} \\ \Rightarrow 4x^2 - 4ax + a^2 + 4y^2 - 4by + b^2 &= a^2 + b^2 \\ \Rightarrow 4x^2 + 4y^2 - 4ax - 4by &= 0 \\ \Rightarrow x^2 + y^2 - ax - by &= 0 \end{aligned}$$

Question 14:

Find the equation of a circle with centre (2, 2) and passes through the point (4, 5).

Answer:

The centre of the circle is given as (h, k) = (2, 2).

Since the circle passes through point (4, 5), the radius (r) of the circle is the distance between the points (2, 2) and (4, 5).

$$\therefore r = \sqrt{(2-4)^2 + (2-5)^2} = \sqrt{(-2)^2 + (-3)^2} = \sqrt{4+9} = \sqrt{13}$$

Thus, the equation of the circle is

$$\begin{aligned} (x-h)^2 + (y-k)^2 &= r^2 \\ (x-2)^2 + (y-2)^2 &= (\sqrt{13})^2 \\ x^2 - 4x + 4 + y^2 - 4y + 4 &= 13 \\ x^2 + y^2 - 4x - 4y - 5 &= 0 \end{aligned}$$

Question 15:

Does the point (-2.5, 3.5) lie inside, outside or on the circle $x^2 + y^2 = 25$?

Answer:

The equation of the given circle is $x^2 + y^2 = 25$.

$$x^2 + y^2 = 25$$

$\Rightarrow (x-0)^2 + (y-0)^2 = 5^2$, which is of the form $(x-h)^2 + (y-k)^2 = r^2$, where $h = 0$, $k = 0$, and $r = 5$.

\therefore Centre = (0, 0) and radius = 5

Distance between point (-2.5, 3.5) and centre (0, 0)

$$\begin{aligned} &= \sqrt{(-2.5-0)^2 + (3.5-0)^2} \\ &= \sqrt{6.25 + 12.25} \\ &= \sqrt{18.5} \\ &= 4.3 \text{ (approx.)} < 5 \end{aligned}$$

Since the distance between point $(-2.5, 3.5)$ and centre $(0, 0)$ of the circle is less than the radius of the circle, point $(-2.5, 3.5)$ lies inside the circle.

Page No 246:

Question 1:

Find the coordinates of the focus, axis of the parabola, the equation of directrix and the length of the latus rectum for $y^2 = 12x$

Answer:

The given equation is $y^2 = 12x$.

Here, the coefficient of x is positive. Hence, the parabola opens towards the right.

On comparing this equation with $y^2 = 4ax$, we obtain

$$4a = 12 \Rightarrow a = 3$$

\therefore Coordinates of the focus = $(a, 0) = (3, 0)$

Since the given equation involves y^2 , the axis of the parabola is the x -axis.

Equation of directrix, $x = -a$ i.e., $x = -3$ i.e., $x + 3 = 0$

Length of latus rectum = $4a = 4 \times 3 = 12$

Question 2:

Find the coordinates of the focus, axis of the parabola, the equation of directrix and the length of the latus rectum for $x^2 = 6y$

Answer:

The given equation is $x^2 = 6y$.

Here, the coefficient of y is positive. Hence, the parabola opens upwards.

On comparing this equation with $x^2 = 4ay$, we obtain

$$4a = 6 \Rightarrow a = \frac{3}{2}$$

∴ Coordinates of the focus = (0, a) = $\left(0, \frac{3}{2}\right)$

Since the given equation involves x^2 , the axis of the parabola is the y-axis.

Equation of directrix, $y = -a$ i.e., $y = -\frac{3}{2}$

Length of latus rectum = $4a = 6$

Question 3:

Find the coordinates of the focus, axis of the parabola, the equation of directrix and the length of the latus rectum for $y^2 = -8x$

Answer:

The given equation is $y^2 = -8x$.

Here, the coefficient of x is negative. Hence, the parabola opens towards the left.

On comparing this equation with $y^2 = -4ax$, we obtain

$$-4a = -8 \Rightarrow a = 2$$

∴ Coordinates of the focus = $(-a, 0) = (-2, 0)$

Since the given equation involves y^2 , the axis of the parabola is the x-axis.

Equation of directrix, $x = a$ i.e., $x = 2$

Length of latus rectum = $4a = 8$

Question 4:

Find the coordinates of the focus, axis of the parabola, the equation of directrix and the length of the latus rectum for $x^2 = -16y$

Answer:

The given equation is $x^2 = -16y$.

Here, the coefficient of y is negative. Hence, the parabola opens downwards.

On comparing this equation with $x^2 = -4ay$, we obtain

$$-4a = -16 \Rightarrow a = 4$$

∴ Coordinates of the focus = $(0, -a) = (0, -4)$

Since the given equation involves x^2 , the axis of the parabola is the y-axis.

Equation of directrix, $y = a$ i.e., $y = 4$

Length of latus rectum $= 4a = 16$

Question 5:

Find the coordinates of the focus, axis of the parabola, the equation of directrix and the length of the latus rectum for $y^2 = 10x$

Answer:

The given equation is $y^2 = 10x$.

Here, the coefficient of x is positive. Hence, the parabola opens towards the right.

On comparing this equation with $y^2 = 4ax$, we obtain

$$4a = 10 \Rightarrow a = \frac{5}{2}$$

$$\therefore \text{Coordinates of the focus} = (a, 0) = \left(\frac{5}{2}, 0\right)$$

Since the given equation involves y^2 , the axis of the parabola is the x -axis.

$$\text{Equation of directrix, } x = -a, \text{ i.e., } x = -\frac{5}{2}$$

Length of latus rectum $= 4a = 10$

Question 6:

Find the coordinates of the focus, axis of the parabola, the equation of directrix and the length of the latus rectum for $x^2 = -9y$

Answer:

The given equation is $x^2 = -9y$.

Here, the coefficient of y is negative. Hence, the parabola opens downwards.

On comparing this equation with $x^2 = -4ay$, we obtain

$$-4a = -9 \Rightarrow a = \frac{9}{4}$$

$$\therefore \text{Coordinates of the focus} = (0, -a) = \left(0, -\frac{9}{4}\right)$$

Since the given equation involves x^2 , the axis of the parabola is the y -axis.

Equation of directrix, $y = a$, i.e., $y = \frac{9}{4}$

Length of latus rectum = $4a = 9$

Page No 247:

Question 7:

Find the equation of the parabola that satisfies the following conditions: Focus (6, 0);
directrix $x = -6$

Answer:

Focus (6, 0); directrix, $x = -6$

Since the focus lies on the x-axis, the x-axis is the axis of the parabola.

Therefore, the equation of the parabola is either of the form $y^2 = 4ax$ or
 $y^2 = -4ax$.

It is also seen that the directrix, $x = -6$ is to the left of the y-axis, while the focus (6, 0) is to
the right of the y-axis. Hence, the parabola is of the form $y^2 = 4ax$.

Here, $a = 6$

Thus, the equation of the parabola is $y^2 = 24x$.

Question 8:

Find the equation of the parabola that satisfies the following conditions: Focus (0, -3);
directrix $y = 3$

Answer:

Focus = (0, -3); directrix $y = 3$

Since the focus lies on the y-axis, the y-axis is the axis of the parabola.

Therefore, the equation of the parabola is either of the form $x^2 = 4ay$ or
 $x^2 = -4ay$.

It is also seen that the directrix, $y = 3$ is above the x-axis, while the focus
(0, -3) is below the x-axis. Hence, the parabola is of the form $x^2 = -4ay$.

Here, $a = 3$

Thus, the equation of the parabola is $x^2 = -12y$.

Question 9:

Find the equation of the parabola that satisfies the following conditions: Vertex (0, 0); focus (3, 0)

Answer:

Vertex (0, 0); focus (3, 0)

Since the vertex of the parabola is (0, 0) and the focus lies on the positive x-axis, x-axis is the axis of the parabola, while the equation of the parabola is of the form $y^2 = 4ax$.

Since the focus is (3, 0), $a = 3$.

Thus, the equation of the parabola is $y^2 = 4 \times 3 \times x$, i.e., $y^2 = 12x$

Question 10:

Find the equation of the parabola that satisfies the following conditions: Vertex (0, 0) focus (-2, 0)

Answer:

Vertex (0, 0) focus (-2, 0)

Since the vertex of the parabola is (0, 0) and the focus lies on the negative x-axis, x-axis is the axis of the parabola, while the equation of the parabola is of the form $y^2 = -4ax$.

Since the focus is (-2, 0), $a = 2$.

Thus, the equation of the parabola is $y^2 = -4(2)x$, i.e., $y^2 = -8x$

Question 11:

Find the equation of the parabola that satisfies the following conditions: Vertex (0, 0) passing through (2, 3) and axis is along x-axis

Answer:

Since the vertex is (0, 0) and the axis of the parabola is the x-axis, the equation of the parabola is either of the form $y^2 = 4ax$ or $y^2 = -4ax$.

The parabola passes through point (2, 3), which lies in the first quadrant.

Therefore, the equation of the parabola is of the form $y^2 = 4ax$, while point

(2, 3) must satisfy the equation $y^2 = 4ax$.

$$\therefore 3^2 = 4a(2) \Rightarrow a = \frac{9}{8}$$

Thus, the equation of the parabola is

$$y^2 = 4\left(\frac{9}{8}\right)x$$

$$y^2 = \frac{9}{2}x$$

$$2y^2 = 9x$$

Question 12:

Find the equation of the parabola that satisfies the following conditions: Vertex (0, 0), passing through (5, 2) and symmetric with respect to y-axis

Answer:

Since the vertex is (0, 0) and the parabola is symmetric about the y-axis, the equation of the parabola is either of the form $x^2 = 4ay$ or $x^2 = -4ay$.

The parabola passes through point (5, 2), which lies in the first quadrant.

Therefore, the equation of the parabola is of the form $x^2 = 4ay$, while point

(5, 2) must satisfy the equation $x^2 = 4ay$.

$$\therefore (5)^2 = 4 \times a \times 2 \Rightarrow 25 = 8a \Rightarrow a = \frac{25}{8}$$

Thus, the equation of the parabola is

$$x^2 = 4\left(\frac{25}{8}\right)y$$

$$2x^2 = 25y$$

Page No 255:

Question 1:

Find the coordinates of the foci, the vertices, the length of major axis, the minor axis, the

eccentricity and the length of the latus rectum of the ellipse $\frac{x^2}{36} + \frac{y^2}{16} = 1$

Answer:

The given equation is $\frac{x^2}{36} + \frac{y^2}{16} = 1$.

Here, the denominator of $\frac{x^2}{36}$ is greater than the denominator of $\frac{y^2}{16}$.

Therefore, the major axis is along the x-axis, while the minor axis is along the y-axis.

On comparing the given equation with $\frac{x^2}{a^2} + \frac{y^2}{b^2} = 1$, we obtain $a = 6$ and $b = 4$.

$$\therefore c = \sqrt{a^2 - b^2} = \sqrt{36 - 16} = \sqrt{20} = 2\sqrt{5}$$

Therefore,

The coordinates of the foci are $(2\sqrt{5}, 0)$ and $(-2\sqrt{5}, 0)$.

The coordinates of the vertices are $(6, 0)$ and $(-6, 0)$.

$$\text{Length of major axis} = 2a = 12$$

$$\text{Length of minor axis} = 2b = 8$$

$$\text{Eccentricity, } e = \frac{c}{a} = \frac{2\sqrt{5}}{6} = \frac{\sqrt{5}}{3}$$

$$\text{Length of latus rectum} = \frac{2b^2}{a} = \frac{2 \times 16}{6} = \frac{16}{3}$$

Question 2:

Find the coordinates of the foci, the vertices, the length of major axis, the minor axis, the

eccentricity and the length of the latus rectum of the ellipse $\frac{x^2}{4} + \frac{y^2}{25} = 1$

Answer:

The given equation is $\frac{x^2}{4} + \frac{y^2}{25} = 1$ or $\frac{x^2}{2^2} + \frac{y^2}{5^2} = 1$.

Here, the denominator of $\frac{y^2}{25}$ is greater than the denominator of $\frac{x^2}{4}$.

Therefore, the major axis is along the y-axis, while the minor axis is along the x-axis.

On comparing the given equation with $\frac{x^2}{b^2} + \frac{y^2}{a^2} = 1$, we obtain $b = 2$ and $a = 5$.

$$\therefore c = \sqrt{a^2 - b^2} = \sqrt{25 - 4} = \sqrt{21}$$

Therefore,

The coordinates of the foci are $(0, \sqrt{21})$ and $(0, -\sqrt{21})$.

The coordinates of the vertices are $(0, 5)$ and $(0, -5)$

Length of major axis = $2a = 10$

Length of minor axis = $2b = 4$

$$\text{Eccentricity, } e = \frac{c}{a} = \frac{\sqrt{21}}{5}$$

$$\text{Length of latus rectum} = \frac{2b^2}{a} = \frac{2 \times 4}{5} = \frac{8}{5}$$

Question 3:

Find the coordinates of the foci, the vertices, the length of major axis, the minor axis, the

eccentricity and the length of the latus rectum of the ellipse $\frac{x^2}{16} + \frac{y^2}{9} = 1$

Answer:

The given equation is $\frac{x^2}{16} + \frac{y^2}{9} = 1$ or $\frac{x^2}{4^2} + \frac{y^2}{3^2} = 1$.

Here, the denominator of $\frac{x^2}{16}$ is greater than the denominator of $\frac{y^2}{9}$.

Therefore, the major axis is along the x-axis, while the minor axis is along the y-axis.

On comparing the given equation with $\frac{x^2}{a^2} + \frac{y^2}{b^2} = 1$, we obtain $a = 4$ and $b = 3$.

$$\therefore c = \sqrt{a^2 - b^2} = \sqrt{16 - 9} = \sqrt{7}$$

Therefore,

The coordinates of the foci are $(\pm\sqrt{7}, 0)$.

The coordinates of the vertices are $(\pm 4, 0)$.

Length of major axis = $2a = 8$

Length of minor axis = $2b = 6$

$$\text{Eccentricity, } e = \frac{c}{a} = \frac{\sqrt{7}}{4}$$

$$\text{Length of latus rectum} = \frac{2b^2}{a} = \frac{2 \times 9}{4} = \frac{9}{2}$$

Question 4:

Find the coordinates of the foci, the vertices, the length of major axis, the minor axis, the eccentricity and the length of the latus rectum of the ellipse $\frac{x^2}{25} + \frac{y^2}{100} = 1$

Answer:

The given equation is $\frac{x^2}{25} + \frac{y^2}{100} = 1$ or $\frac{x^2}{5^2} + \frac{y^2}{10^2} = 1$.

Here, the denominator of $\frac{y^2}{100}$ is greater than the denominator of $\frac{x^2}{25}$.

Therefore, the major axis is along the y-axis, while the minor axis is along the x-axis.

On comparing the given equation with $\frac{x^2}{b^2} + \frac{y^2}{a^2} = 1$, we obtain $b = 5$ and $a = 10$.

$$\therefore c = \sqrt{a^2 - b^2} = \sqrt{100 - 25} = \sqrt{75} = 5\sqrt{3}$$

Therefore,

The coordinates of the foci are $(0, \pm 5\sqrt{3})$.

The coordinates of the vertices are $(0, \pm 10)$.

Length of major axis = $2a = 20$

Length of minor axis = $2b = 10$

$$\text{Eccentricity, } e = \frac{c}{a} = \frac{5\sqrt{3}}{10} = \frac{\sqrt{3}}{2}$$

$$\text{Length of latus rectum} = \frac{2b^2}{a} = \frac{2 \times 25}{10} = 5$$

Question 5:

Find the coordinates of the foci, the vertices, the length of major axis, the minor axis, the eccentricity and the length of the latus rectum of the ellipse $\frac{x^2}{49} + \frac{y^2}{36} = 1$

Answer:

The given equation is $\frac{x^2}{49} + \frac{y^2}{36} = 1$ or $\frac{x^2}{7^2} + \frac{y^2}{6^2} = 1$.

Here, the denominator of $\frac{x^2}{49}$ is greater than the denominator of $\frac{y^2}{36}$.

Therefore, the major axis is along the x-axis, while the minor axis is along the y-axis.

On comparing the given equation with $\frac{x^2}{a^2} + \frac{y^2}{b^2} = 1$, we obtain $a = 7$ and $b = 6$.

$$\therefore c = \sqrt{a^2 - b^2} = \sqrt{49 - 36} = \sqrt{13}$$

Therefore,

The coordinates of the foci are $(\pm\sqrt{13}, 0)$.

The coordinates of the vertices are $(\pm 7, 0)$.

Length of major axis = $2a = 14$

Length of minor axis = $2b = 12$

$$\text{Eccentricity, } e = \frac{c}{a} = \frac{\sqrt{13}}{7}$$

$$\text{Length of latus rectum} = \frac{2b^2}{a} = \frac{2 \times 36}{7} = \frac{72}{7}$$

Question 6:

Find the coordinates of the foci, the vertices, the length of major axis, the minor axis, the

eccentricity and the length of the latus rectum of the ellipse $\frac{x^2}{100} + \frac{y^2}{400} = 1$

Answer:

The given equation is $\frac{x^2}{100} + \frac{y^2}{400} = 1$ or $\frac{x^2}{10^2} + \frac{y^2}{20^2} = 1$.

Here, the denominator of $\frac{y^2}{400}$ is greater than the denominator of $\frac{x^2}{100}$.

Therefore, the major axis is along the y-axis, while the minor axis is along the x-axis.

On comparing the given equation with $\frac{x^2}{b^2} + \frac{y^2}{a^2} = 1$, we obtain $b = 10$ and $a = 20$.

$$\therefore c = \sqrt{a^2 - b^2} = \sqrt{400 - 100} = \sqrt{300} = 10\sqrt{3}$$

Therefore,

The coordinates of the foci are $(0, \pm 10\sqrt{3})$.

The coordinates of the vertices are $(0, \pm 20)$

Length of major axis = $2a = 40$

Length of minor axis = $2b = 20$

Eccentricity, $e = \frac{c}{a} = \frac{10\sqrt{3}}{20} = \frac{\sqrt{3}}{2}$

Length of latus rectum $= \frac{2b^2}{a} = \frac{2 \times 100}{20} = 10$

Question 7:

Find the coordinates of the foci, the vertices, the length of major axis, the minor axis, the eccentricity and the length of the latus rectum of the ellipse $36x^2 + 4y^2 = 144$

Answer:

The given equation is $36x^2 + 4y^2 = 144$.

It can be written as

$$36x^2 + 4y^2 = 144$$

$$\text{Or, } \frac{x^2}{4} + \frac{y^2}{36} = 1$$

$$\text{Or, } \frac{x^2}{2^2} + \frac{y^2}{6^2} = 1 \quad \dots(1)$$

Here, the denominator of $\frac{y^2}{6^2}$ is greater than the denominator of $\frac{x^2}{2^2}$.

Therefore, the major axis is along the y-axis, while the minor axis is along the x-axis.

On comparing equation (1) with $\frac{x^2}{b^2} + \frac{y^2}{a^2} = 1$, we obtain $b = 2$ and $a = 6$.

$$\therefore c = \sqrt{a^2 - b^2} = \sqrt{36 - 4} = \sqrt{32} = 4\sqrt{2}$$

Therefore,

The coordinates of the foci are $(0, \pm 4\sqrt{2})$.

The coordinates of the vertices are $(0, \pm 6)$.

Length of major axis = $2a = 12$

Length of minor axis = $2b = 4$

$$\text{Eccentricity, } e = \frac{c}{a} = \frac{4\sqrt{2}}{6} = \frac{2\sqrt{2}}{3}$$

$$\text{Length of latus rectum} = \frac{2b^2}{a} = \frac{2 \times 4}{6} = \frac{4}{3}$$

Question 8:

Find the coordinates of the foci, the vertices, the length of major axis, the minor axis, the eccentricity and the length of the latus rectum of the ellipse $16x^2 + y^2 = 16$

Answer:

The given equation is $16x^2 + y^2 = 16$.

It can be written as

$$16x^2 + y^2 = 16$$

$$\text{Or, } \frac{x^2}{1} + \frac{y^2}{16} = 1$$

$$\text{Or, } \frac{x^2}{1^2} + \frac{y^2}{4^2} = 1 \quad \dots(1)$$

Here, the denominator of $\frac{y^2}{4^2}$ is greater than the denominator of $\frac{x^2}{1^2}$.

Therefore, the major axis is along the y-axis, while the minor axis is along the x-axis.

On comparing equation (1) with $\frac{x^2}{b^2} + \frac{y^2}{a^2} = 1$, we obtain $b = 1$ and $a = 4$.

$$\therefore c = \sqrt{a^2 - b^2} = \sqrt{16 - 1} = \sqrt{15}$$

Therefore,

The coordinates of the foci are $(0, \pm\sqrt{15})$.

The coordinates of the vertices are $(0, \pm 4)$.

Length of major axis = $2a = 8$

Length of minor axis = $2b = 2$

$$\text{Eccentricity, } e = \frac{c}{a} = \frac{\sqrt{15}}{4}$$

$$\text{Length of latus rectum} = \frac{2b^2}{a} = \frac{2 \times 1}{4} = \frac{1}{2}$$

Question 9:

Find the coordinates of the foci, the vertices, the length of major axis, the minor axis, the eccentricity and the length of the latus rectum of the ellipse $4x^2 + 9y^2 = 36$

Answer:

The given equation is $4x^2 + 9y^2 = 36$.

It can be written as

$$4x^2 + 9y^2 = 36$$
$$\text{Or, } \frac{x^2}{9} + \frac{y^2}{4} = 1$$
$$\text{Or, } \frac{x^2}{3^2} + \frac{y^2}{2^2} = 1 \quad \dots(1)$$

Here, the denominator of $\frac{x^2}{3^2}$ is greater than the denominator of $\frac{y^2}{2^2}$.

Therefore, the major axis is along the x-axis, while the minor axis is along the y-axis.

On comparing the given equation with $\frac{x^2}{a^2} + \frac{y^2}{b^2} = 1$, we obtain $a = 3$ and $b = 2$.

$$\therefore c = \sqrt{a^2 - b^2} = \sqrt{9 - 4} = \sqrt{5}$$

Therefore,

The coordinates of the foci are $(\pm\sqrt{5}, 0)$.

The coordinates of the vertices are $(\pm 3, 0)$.

Length of major axis = $2a = 6$

Length of minor axis = $2b = 4$

$$\text{Eccentricity, } e = \frac{c}{a} = \frac{\sqrt{5}}{3}$$

$$\text{Length of latus rectum} = \frac{2b^2}{a} = \frac{2 \times 4}{3} = \frac{8}{3}$$

Question 10:

Find the equation for the ellipse that satisfies the given conditions: Vertices $(\pm 5, 0)$, foci $(\pm 4, 0)$

Answer:

Vertices $(\pm 5, 0)$, foci $(\pm 4, 0)$

Here, the vertices are on the x-axis.

Therefore, the equation of the ellipse will be of the form $\frac{x^2}{a^2} + \frac{y^2}{b^2} = 1$, where a is the semi-major axis.

Accordingly, $a = 5$ and $c = 4$.

It is known that $a^2 = b^2 + c^2$.

$$\therefore 5^2 = b^2 + 4^2$$

$$\Rightarrow 25 = b^2 + 16$$

$$\Rightarrow b^2 = 25 - 16$$

$$\Rightarrow b = \sqrt{9} = 3$$

Thus, the equation of the ellipse is $\frac{x^2}{5^2} + \frac{y^2}{3^2} = 1$ or $\frac{x^2}{25} + \frac{y^2}{9} = 1$.

Question 11:

Find the equation for the ellipse that satisfies the given conditions: Vertices $(0, \pm 13)$, foci $(0, \pm 5)$

Answer:

Vertices $(0, \pm 13)$, foci $(0, \pm 5)$

Here, the vertices are on the y-axis.

Therefore, the equation of the ellipse will be of the form $\frac{x^2}{b^2} + \frac{y^2}{a^2} = 1$, where a is the semi-major axis.

Accordingly, $a = 13$ and $c = 5$.

It is known that $a^2 = b^2 + c^2$.

$$\therefore 13^2 = b^2 + 5^2$$

$$\Rightarrow 169 = b^2 + 25$$

$$\Rightarrow b^2 = 169 - 25$$

$$\Rightarrow b = \sqrt{144} = 12$$

Thus, the equation of the ellipse is $\frac{x^2}{12^2} + \frac{y^2}{13^2} = 1$ or $\frac{x^2}{144} + \frac{y^2}{169} = 1$.

Question 12:

Find the equation for the ellipse that satisfies the given conditions: Vertices $(\pm 6, 0)$, foci $(\pm 4, 0)$

Answer:

Vertices $(\pm 6, 0)$, foci $(\pm 4, 0)$

Here, the vertices are on the x-axis.

Therefore, the equation of the ellipse will be of the form $\frac{x^2}{a^2} + \frac{y^2}{b^2} = 1$, where a is the semi-major axis.

Accordingly, $a = 6$, $c = 4$.

It is known that $a^2 = b^2 + c^2$.

$$\therefore 6^2 = b^2 + 4^2$$

$$\Rightarrow 36 = b^2 + 16$$

$$\Rightarrow b^2 = 36 - 16$$

$$\Rightarrow b = \sqrt{20}$$

$$\frac{x^2}{6^2} + \frac{y^2}{(\sqrt{20})^2} = 1 \text{ or } \frac{x^2}{36} + \frac{y^2}{20} = 1$$

Thus, the equation of the ellipse is

Question 13:

Find the equation for the ellipse that satisfies the given conditions: Ends of major axis $(\pm 3, 0)$, ends of minor axis $(0, \pm 2)$

Answer:

Ends of major axis $(\pm 3, 0)$, ends of minor axis $(0, \pm 2)$

Here, the major axis is along the x-axis.

Therefore, the equation of the ellipse will be of the form $\frac{x^2}{a^2} + \frac{y^2}{b^2} = 1$, where a is the semi-major axis.

Accordingly, $a = 3$ and $b = 2$.

Thus, the equation of the ellipse is $\frac{x^2}{3^2} + \frac{y^2}{2^2} = 1$ i.e., $\frac{x^2}{9} + \frac{y^2}{4} = 1$.

Question 14:

Find the equation for the ellipse that satisfies the given conditions: Ends of major axis

$(0, \pm\sqrt{5})$, ends of minor axis $(\pm 1, 0)$

Answer:

Ends of major axis $(0, \pm\sqrt{5})$, ends of minor axis $(\pm 1, 0)$

Here, the major axis is along the y-axis.

Therefore, the equation of the ellipse will be of the form $\frac{x^2}{b^2} + \frac{y^2}{a^2} = 1$, where a is the semi-major axis.

Accordingly, $a = \sqrt{5}$ and $b = 1$.

$$\frac{x^2}{1^2} + \frac{y^2}{(\sqrt{5})^2} = 1 \text{ or } \frac{x^2}{1} + \frac{y^2}{5} = 1$$

Thus, the equation of the ellipse is

Question 15:

Find the equation for the ellipse that satisfies the given conditions: Length of major axis 26, foci $(\pm 5, 0)$

Answer:

Length of major axis = 26; foci = $(\pm 5, 0)$.

Since the foci are on the x-axis, the major axis is along the x-axis.

Therefore, the equation of the ellipse will be of the form $\frac{x^2}{a^2} + \frac{y^2}{b^2} = 1$, where a is the semi-major axis.

Accordingly, $2a = 26 \Rightarrow a = 13$ and $c = 5$.

It is known that $a^2 = b^2 + c^2$.

$$\therefore 13^2 = b^2 + 5^2$$

$$\Rightarrow 169 = b^2 + 25$$

$$\Rightarrow b^2 = 169 - 25$$

$$\Rightarrow b = \sqrt{144} = 12$$

Thus, the equation of the ellipse is $\frac{x^2}{13^2} + \frac{y^2}{12^2} = 1$ or $\frac{x^2}{169} + \frac{y^2}{144} = 1$.

Question 16:

Find the equation for the ellipse that satisfies the given conditions: Length of minor axis 16, foci $(0, \pm 6)$

Answer:

Length of minor axis = 16; foci = $(0, \pm 6)$.

Since the foci are on the y-axis, the major axis is along the y-axis.

Therefore, the equation of the ellipse will be of the form $\frac{x^2}{b^2} + \frac{y^2}{a^2} = 1$, where a is the semi-major axis.

Accordingly, $2b = 16 \Rightarrow b = 8$ and $c = 6$.

It is known that $a^2 = b^2 + c^2$.

$$\therefore a^2 = 8^2 + 6^2 = 64 + 36 = 100$$

$$\Rightarrow a = \sqrt{100} = 10$$

Thus, the equation of the ellipse is $\frac{x^2}{8^2} + \frac{y^2}{10^2} = 1$ or $\frac{x^2}{64} + \frac{y^2}{100} = 1$.

Question 17:

Find the equation for the ellipse that satisfies the given conditions: Foci $(\pm 3, 0)$, $a = 4$

Answer:

Foci $(\pm 3, 0)$, $a = 4$

Since the foci are on the x-axis, the major axis is along the x-axis.

Therefore, the equation of the ellipse will be of the form $\frac{x^2}{a^2} + \frac{y^2}{b^2} = 1$, where a is the semi-major axis.

Accordingly, $c = 3$ and $a = 4$.

It is known that $a^2 = b^2 + c^2$.

$$\therefore 4^2 = b^2 + 3^2$$

$$\Rightarrow 16 = b^2 + 9$$

$$\Rightarrow b^2 = 16 - 9 = 7$$

Thus, the equation of the ellipse is $\frac{x^2}{16} + \frac{y^2}{7} = 1$.

Question 18:

Find the equation for the ellipse that satisfies the given conditions: $b = 3$, $c = 4$, centre at the origin; foci on the x axis.

Answer:

It is given that $b = 3$, $c = 4$, centre at the origin; foci on the x axis.

Since the foci are on the x-axis, the major axis is along the x-axis.

Therefore, the equation of the ellipse will be of the form $\frac{x^2}{a^2} + \frac{y^2}{b^2} = 1$, where a is the semi-major axis.

Accordingly, $b = 3$, $c = 4$.

It is known that $a^2 = b^2 + c^2$.

$$\therefore a^2 = 3^2 + 4^2 = 9 + 16 = 25$$

$$\Rightarrow a = 5$$

Thus, the equation of the ellipse is $\frac{x^2}{5^2} + \frac{y^2}{3^2} = 1$ or $\frac{x^2}{25} + \frac{y^2}{9} = 1$.

Question 19:

Find the equation for the ellipse that satisfies the given conditions: Centre at $(0, 0)$, major axis on the y-axis and passes through the points $(3, 2)$ and $(1, 6)$.

Answer:

Since the centre is at $(0, 0)$ and the major axis is on the y-axis, the equation of the ellipse will be of the form

$$\frac{x^2}{b^2} + \frac{y^2}{a^2} = 1 \quad \dots(1)$$

Where, a is the semi-major axis

The ellipse passes through points $(3, 2)$ and $(1, 6)$. Hence,

$$\frac{9}{b^2} + \frac{4}{a^2} = 1 \quad \dots(2)$$

$$\frac{1}{b^2} + \frac{36}{a^2} = 1 \quad \dots(3)$$

On solving equations (2) and (3), we obtain $b^2 = 10$ and $a^2 = 40$.

Thus, the equation of the ellipse is $\frac{x^2}{10} + \frac{y^2}{40} = 1$ or $4x^2 + y^2 = 40$.

Question 20:

Find the equation for the ellipse that satisfies the given conditions: Major axis on the x-axis and passes through the points (4, 3) and (6, 2).

Answer:

Since the major axis is on the x-axis, the equation of the ellipse will be of the form

$$\frac{x^2}{a^2} + \frac{y^2}{b^2} = 1 \quad \dots(1)$$

Where, a is the semi-major axis

The ellipse passes through points (4, 3) and (6, 2). Hence,

$$\frac{16}{a^2} + \frac{9}{b^2} = 1 \quad \dots(2)$$

$$\frac{36}{a^2} + \frac{4}{b^2} = 1 \quad \dots(3)$$

On solving equations (2) and (3), we obtain $a^2 = 52$ and $b^2 = 13$.

Thus, the equation of the ellipse is $\frac{x^2}{52} + \frac{y^2}{13} = 1$ or $x^2 + 4y^2 = 52$.

Page No 262:

Question 1:

Find the coordinates of the foci and the vertices, the eccentricity, and the length of the latus

rectum of the hyperbola $\frac{x^2}{16} - \frac{y^2}{9} = 1$

Answer:

The given equation is $\frac{x^2}{16} - \frac{y^2}{9} = 1$ or $\frac{x^2}{4^2} - \frac{y^2}{3^2} = 1$.

On comparing this equation with the standard equation of hyperbola i.e., $\frac{x^2}{a^2} - \frac{y^2}{b^2} = 1$, we obtain $a = 4$ and $b = 3$.

We know that $a^2 + b^2 = c^2$.

$$\therefore c^2 = 4^2 + 3^2 = 25$$

$$\Rightarrow c = 5$$

Therefore,

The coordinates of the foci are $(\pm 5, 0)$.

The coordinates of the vertices are $(\pm 4, 0)$.

$$\text{Eccentricity, } e = \frac{c}{a} = \frac{5}{4}$$

$$\text{Length of latus rectum} = \frac{2b^2}{a} = \frac{2 \times 9}{4} = \frac{9}{2}$$

Question 2:

Find the coordinates of the foci and the vertices, the eccentricity, and the length of the latus

$$\text{rectum of the hyperbola } \frac{y^2}{9} - \frac{x^2}{27} = 1$$

Answer:

$$\frac{y^2}{9} - \frac{x^2}{27} = 1 \text{ or } \frac{y^2}{3^2} - \frac{x^2}{(\sqrt{27})^2} = 1$$

The given equation is

On comparing this equation with the standard equation of hyperbola i.e., $\frac{y^2}{a^2} - \frac{x^2}{b^2} = 1$, we obtain $a = 3$ and $b = \sqrt{27}$.

We know that $a^2 + b^2 = c^2$.

$$\therefore c^2 = 3^2 + (\sqrt{27})^2 = 9 + 27 = 36$$

$$\Rightarrow c = 6$$

Therefore,

The coordinates of the foci are $(0, \pm 6)$.

The coordinates of the vertices are $(0, \pm 3)$.

$$\text{Eccentricity, } e = \frac{c}{a} = \frac{6}{3} = 2$$

$$\text{Length of latus rectum} = \frac{2b^2}{a} = \frac{2 \times 27}{3} = 18$$

Question 3:

Find the coordinates of the foci and the vertices, the eccentricity, and the length of the latus

$$\text{rectum of the hyperbola } 9y^2 - 4x^2 = 36$$

Answer:

The given equation is $9y^2 - 4x^2 = 36$.

It can be written as

$$9y^2 - 4x^2 = 36$$

$$\text{Or, } \frac{y^2}{4} - \frac{x^2}{9} = 1$$

$$\text{Or, } \frac{y^2}{2^2} - \frac{x^2}{3^2} = 1 \quad \dots(1)$$

On comparing equation (1) with the standard equation of hyperbola i.e., $\frac{y^2}{a^2} - \frac{x^2}{b^2} = 1$, we obtain $a = 2$ and $b = 3$.

We know that $a^2 + b^2 = c^2$.

$$\therefore c^2 = 4 + 9 = 13$$

$$\Rightarrow c = \sqrt{13}$$

Therefore,

The coordinates of the foci are $(0, \pm\sqrt{13})$.

The coordinates of the vertices are $(0, \pm 2)$.

$$\text{Eccentricity, } e = \frac{c}{a} = \frac{\sqrt{13}}{2}$$

$$\text{Length of latus rectum} = \frac{2b^2}{a} = \frac{2 \times 9}{2} = 9$$

Question 4:

Find the coordinates of the foci and the vertices, the eccentricity, and the length of the latus rectum of the hyperbola $16x^2 - 9y^2 = 576$

Answer:

The given equation is $16x^2 - 9y^2 = 576$.

It can be written as

$$16x^2 - 9y^2 = 576$$

$$\Rightarrow \frac{x^2}{36} - \frac{y^2}{64} = 1$$

$$\Rightarrow \frac{x^2}{6^2} - \frac{y^2}{8^2} = 1 \quad \dots(1)$$

On comparing equation (1) with the standard equation of hyperbola i.e., $\frac{x^2}{a^2} - \frac{y^2}{b^2} = 1$, we obtain $a = 6$ and $b = 8$.

We know that $a^2 + b^2 = c^2$.

$$\therefore c^2 = 36 + 64 = 100$$
$$\Rightarrow c = 10$$

Therefore,

The coordinates of the foci are $(\pm 10, 0)$.

The coordinates of the vertices are $(\pm 6, 0)$.

$$\text{Eccentricity, } e = \frac{c}{a} = \frac{10}{6} = \frac{5}{3}$$

$$\text{Length of latus rectum} = \frac{2b^2}{a} = \frac{2 \times 64}{6} = \frac{64}{3}$$

Question 5:

Find the coordinates of the foci and the vertices, the eccentricity, and the length of the latus rectum of the hyperbola $5y^2 - 9x^2 = 36$

Answer:

The given equation is $5y^2 - 9x^2 = 36$.

$$\Rightarrow \frac{y^2}{\left(\frac{36}{5}\right)} - \frac{x^2}{4} = 1$$

$$\Rightarrow \frac{y^2}{\left(\frac{6}{\sqrt{5}}\right)^2} - \frac{x^2}{2^2} = 1 \quad \dots(1)$$

On comparing equation (1) with the standard equation of hyperbola i.e., $\frac{y^2}{a^2} - \frac{x^2}{b^2} = 1$, we

obtain $a = \frac{6}{\sqrt{5}}$ and $b = 2$.

We know that $a^2 + b^2 = c^2$.

$$\therefore c^2 = \frac{36}{5} + 4 = \frac{56}{5}$$
$$\Rightarrow c = \sqrt{\frac{56}{5}} = \frac{2\sqrt{14}}{\sqrt{5}}$$

Therefore, the coordinates of the foci are $\left(0, \pm \frac{2\sqrt{14}}{\sqrt{5}}\right)$.

The coordinates of the vertices are $\left(0, \pm \frac{6}{\sqrt{5}}\right)$.

$$\text{Eccentricity, } e = \frac{c}{a} = \frac{\left(\frac{2\sqrt{14}}{\sqrt{5}}\right)}{\left(\frac{6}{\sqrt{5}}\right)} = \frac{\sqrt{14}}{3}$$

$$= \frac{2b^2}{a} = \frac{2 \times 4}{\left(\frac{6}{\sqrt{5}}\right)} = \frac{4\sqrt{5}}{3}$$

Length of latus rectum

Question 6:

Find the coordinates of the foci and the vertices, the eccentricity, and the length of the latus rectum of the hyperbola $49y^2 - 16x^2 = 784$

Answer:

The given equation is $49y^2 - 16x^2 = 784$.

It can be written as $49y^2 - 16x^2 = 784$

$$\text{Or, } \frac{y^2}{16} - \frac{x^2}{49} = 1$$

$$\text{Or, } \frac{y^2}{4^2} - \frac{x^2}{7^2} = 1 \quad \dots(1)$$

On comparing equation (1) with the standard equation of hyperbola i.e., $\frac{y^2}{a^2} - \frac{x^2}{b^2} = 1$, we obtain $a = 4$ and $b = 7$.

We know that $a^2 + b^2 = c^2$.

$$\therefore c^2 = 16 + 49 = 65$$

$$\Rightarrow c = \sqrt{65}$$

Therefore,

The coordinates of the foci are $\left(0, \pm \sqrt{65}\right)$.

The coordinates of the vertices are $(0, \pm 4)$.

$$\text{Eccentricity, } e = \frac{c}{a} = \frac{\sqrt{65}}{4}$$

$$\text{Length of latus rectum} = \frac{2b^2}{a} = \frac{2 \times 49}{4} = \frac{49}{2}$$

Question 7:

Find the equation of the hyperbola satisfying the give conditions: Vertices $(\pm 2, 0)$, foci $(\pm 3, 0)$

Answer:

Vertices $(\pm 2, 0)$, foci $(\pm 3, 0)$

Here, the vertices are on the x-axis.

Therefore, the equation of the hyperbola is of the form $\frac{x^2}{a^2} - \frac{y^2}{b^2} = 1$.

Since the vertices are $(\pm 2, 0)$, $a = 2$.

Since the foci are $(\pm 3, 0)$, $c = 3$.

We know that $a^2 + b^2 = c^2$.

$$\therefore 2^2 + b^2 = 3^2$$

$$b^2 = 9 - 4 = 5$$

Thus, the equation of the hyperbola is $\frac{x^2}{4} - \frac{y^2}{5} = 1$.

Question 8:

Find the equation of the hyperbola satisfying the give conditions: Vertices $(0, \pm 5)$, foci $(0, \pm 8)$

Answer:

Vertices $(0, \pm 5)$, foci $(0, \pm 8)$

Here, the vertices are on the y-axis.

Therefore, the equation of the hyperbola is of the form $\frac{y^2}{a^2} - \frac{x^2}{b^2} = 1$.

Since the vertices are $(0, \pm 5)$, $a = 5$.

Since the foci are $(0, \pm 8)$, $c = 8$.

We know that $a^2 + b^2 = c^2$.

$$\therefore 5^2 + b^2 = 8^2$$

$$b^2 = 64 - 25 = 39$$

Thus, the equation of the hyperbola is $\frac{y^2}{25} - \frac{x^2}{39} = 1$.

Question 9:

Find the equation of the hyperbola satisfying the give conditions: Vertices $(0, \pm 3)$, foci $(0, \pm 5)$

Answer:

Vertices $(0, \pm 3)$, foci $(0, \pm 5)$

Here, the vertices are on the y-axis.

Therefore, the equation of the hyperbola is of the form $\frac{y^2}{a^2} - \frac{x^2}{b^2} = 1$.

Since the vertices are $(0, \pm 3)$, $a = 3$.

Since the foci are $(0, \pm 5)$, $c = 5$.

We know that $a^2 + b^2 = c^2$.

$$\therefore 3^2 + b^2 = 5^2$$

$$\Rightarrow b^2 = 25 - 9 = 16$$

Thus, the equation of the hyperbola is $\frac{y^2}{9} - \frac{x^2}{16} = 1$.

Question 10:

Find the equation of the hyperbola satisfying the give conditions: Foci $(\pm 5, 0)$, the transverse axis is of length 8.

Answer:

Foci $(\pm 5, 0)$, the transverse axis is of length 8.

Here, the foci are on the x-axis.

Therefore, the equation of the hyperbola is of the form $\frac{x^2}{a^2} - \frac{y^2}{b^2} = 1$.

Since the foci are $(\pm 5, 0)$, $c = 5$.

Since the length of the transverse axis is 8, $2a = 8 \Rightarrow a = 4$.

We know that $a^2 + b^2 = c^2$.

$$\therefore 4^2 + b^2 = 5^2$$

$$\Rightarrow b^2 = 25 - 16 = 9$$

Thus, the equation of the hyperbola is $\frac{x^2}{16} - \frac{y^2}{9} = 1$.

Question 11:

Find the equation of the hyperbola satisfying the give conditions: Foci $(0, \pm 13)$, the conjugate axis is of length 24.

Answer:

Foci $(0, \pm 13)$, the conjugate axis is of length 24.

Here, the foci are on the y-axis.

Therefore, the equation of the hyperbola is of the form $\frac{y^2}{a^2} - \frac{x^2}{b^2} = 1$.

Since the foci are $(0, \pm 13)$, $c = 13$.

Since the length of the conjugate axis is 24, $2b = 24 \Rightarrow b = 12$.

We know that $a^2 + b^2 = c^2$.

$$\therefore a^2 + 12^2 = 13^2$$

$$\Rightarrow a^2 = 169 - 144 = 25$$

Thus, the equation of the hyperbola is $\frac{y^2}{25} - \frac{x^2}{144} = 1$.

Question 12:

Find the equation of the hyperbola satisfying the give conditions: Foci $(\pm 3\sqrt{5}, 0)$, the latus rectum is of length 8.

Answer:

Foci $(\pm 3\sqrt{5}, 0)$, the latus rectum is of length 8.

Here, the foci are on the x-axis.

Therefore, the equation of the hyperbola is of the form $\frac{x^2}{a^2} - \frac{y^2}{b^2} = 1$.

Since the foci are $(\pm 3\sqrt{5}, 0)$, $c = \pm 3\sqrt{5}$.

Length of latus rectum = 8

$$\Rightarrow \frac{2b^2}{a} = 8$$

$$\Rightarrow b^2 = 4a$$

We know that $a^2 + b^2 = c^2$.

$$\therefore a^2 + 4a = 45$$

$$\Rightarrow a^2 + 4a - 45 = 0$$

$$\Rightarrow a^2 + 9a - 5a - 45 = 0$$

$$\Rightarrow (a + 9)(a - 5) = 0$$

$$\Rightarrow a = -9, 5$$

Since a is non-negative, $a = 5$.

$$\therefore b^2 = 4a = 4 \times 5 = 20$$

Thus, the equation of the hyperbola is $\frac{x^2}{25} - \frac{y^2}{20} = 1$.

Question 13:

Find the equation of the hyperbola satisfying the give conditions: Foci $(\pm 4, 0)$, the latus rectum is of length 12

Answer:

Foci $(\pm 4, 0)$, the latus rectum is of length 12.

Here, the foci are on the x-axis.

Therefore, the equation of the hyperbola is of the form $\frac{x^2}{a^2} - \frac{y^2}{b^2} = 1$.

Since the foci are $(\pm 4, 0)$, $c = 4$.

Length of latus rectum = 12

$$\Rightarrow \frac{2b^2}{a} = 12$$

$$\Rightarrow b^2 = 6a$$

We know that $a^2 + b^2 = c^2$.

$$\therefore a^2 + 6a = 16$$

$$\Rightarrow a^2 + 6a - 16 = 0$$

$$\Rightarrow a^2 + 8a - 2a - 16 = 0$$

$$\Rightarrow (a + 8)(a - 2) = 0$$

$$\Rightarrow a = -8, 2$$

Since a is non-negative, $a = 2$.

$$\therefore b^2 = 6a = 6 \times 2 = 12$$

Thus, the equation of the hyperbola is $\frac{x^2}{4} - \frac{y^2}{12} = 1$.

Question 14:

Find the equation of the hyperbola satisfying the give conditions: Vertices $(\pm 7, 0)$, $e = \frac{4}{3}$

Answer:

Vertices $(\pm 7, 0)$, $e = \frac{4}{3}$

Here, the vertices are on the x -axis.

Therefore, the equation of the hyperbola is of the form $\frac{x^2}{a^2} - \frac{y^2}{b^2} = 1$.

Since the vertices are $(\pm 7, 0)$, $a = 7$.

It is given that $e = \frac{4}{3}$

$$\therefore \frac{c}{a} = \frac{4}{3} \quad \left[e = \frac{c}{a} \right]$$

$$\Rightarrow \frac{c}{7} = \frac{4}{3}$$

$$\Rightarrow c = \frac{28}{3}$$

We know that $a^2 + b^2 = c^2$.

$$\begin{aligned} \therefore 7^2 + b^2 &= \left(\frac{28}{3}\right)^2 \\ \Rightarrow b^2 &= \frac{784}{9} - 49 \\ \Rightarrow b^2 &= \frac{784 - 441}{9} = \frac{343}{9} \end{aligned}$$

Thus, the equation of the hyperbola is $\frac{x^2}{49} - \frac{9y^2}{343} = 1$.

Question 15:

Find the equation of the hyperbola satisfying the give conditions: Foci $(0, \pm\sqrt{10})$, passing through $(2, 3)$

Answer:

Foci $(0, \pm\sqrt{10})$, passing through $(2, 3)$

Here, the foci are on the y-axis.

Therefore, the equation of the hyperbola is of the form $\frac{y^2}{a^2} - \frac{x^2}{b^2} = 1$.

Since the foci are $(0, \pm\sqrt{10})$, $c = \sqrt{10}$.

We know that $a^2 + b^2 = c^2$.

$$\therefore a^2 + b^2 = 10$$

$$\Rightarrow b^2 = 10 - a^2 \dots (1)$$

Since the hyperbola passes through point $(2, 3)$,

$$\frac{9}{a^2} - \frac{4}{b^2} = 1 \dots (2)$$

From equations (1) and (2), we obtain

$$\frac{9}{a^2} - \frac{4}{(10-a^2)} = 1$$

$$\Rightarrow 9(10-a^2) - 4a^2 = a^2(10-a^2)$$

$$\Rightarrow 90 - 9a^2 - 4a^2 = 10a^2 - a^4$$

$$\Rightarrow a^4 - 23a^2 + 90 = 0$$

$$\Rightarrow a^4 - 18a^2 - 5a^2 + 90 = 0$$

$$\Rightarrow a^2(a^2 - 18) - 5(a^2 - 18) = 0$$

$$\Rightarrow (a^2 - 18)(a^2 - 5) = 0$$

$$\Rightarrow a^2 = 18 \text{ or } 5$$

In hyperbola, $c > a$, i.e., $c^2 > a^2$

$$\therefore a^2 = 5$$

$$\Rightarrow b^2 = 10 - a^2 = 10 - 5 = 5$$

Thus, the equation of the hyperbola is $\frac{y^2}{5} - \frac{x^2}{5} = 1$.

Page No 264:

Question 1:

If a parabolic reflector is 20 cm in diameter and 5 cm deep, find the focus.

Answer:

The origin of the coordinate plane is taken at the vertex of the parabolic reflector in such a way that the axis of the reflector is along the positive x-axis.

This can be diagrammatically represented as

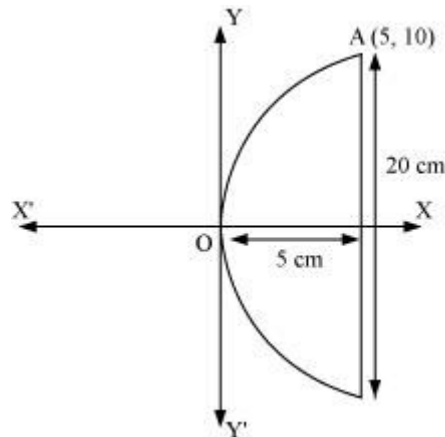

The equation of the parabola is of the form $y^2 = 4ax$ (as it is opening to the right).

$$\text{Since the parabola passes through point A (10, 5), } 10^2 = 4a(5)$$

$$\Rightarrow 100 = 20a$$

$$\Rightarrow a = \frac{100}{20} = 5$$

Therefore, the focus of the parabola is $(a, 0) = (5, 0)$, which is the mid-point of the diameter.

Hence, the focus of the reflector is at the mid-point of the diameter.

Question 1:

If a parabolic reflector is 20 cm in diameter and 5 cm deep, find the focus.

Answer:

The origin of the coordinate plane is taken at the vertex of the parabolic reflector in such a way that the axis of the reflector is along the positive x -axis.

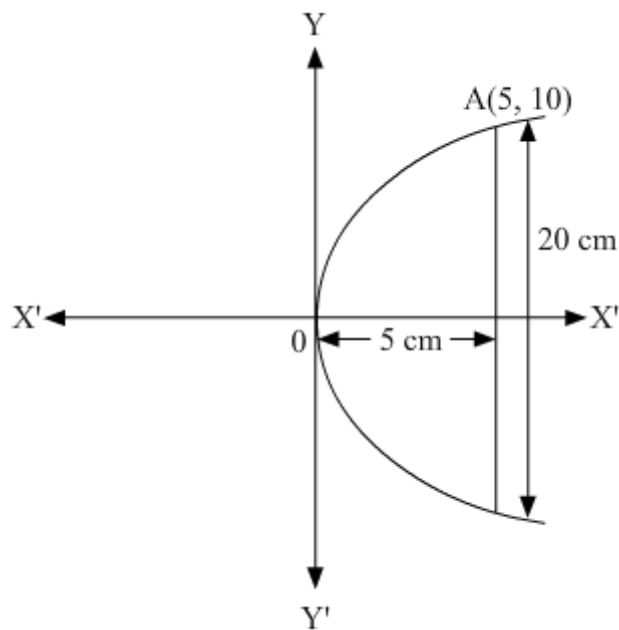

This can be diagrammatically represented as

The equation of the parabola is of the form $y^2 = 4ax$ (as it is opening to the right). Since the parabola passes through point $A(5, 10)$,

$$10^2 = 4a(5)$$

$$\Rightarrow 100 = 20a$$

$$\Rightarrow a = \frac{100}{20} = 5$$

Therefore, the focus of the parabola is $(a, 0) = (5, 0)$, which is the mid-point of the diameter.

Hence, the focus of the reflector is at the mid-point of the diameter.

Question 2:

An arch is in the form of a parabola with its axis vertical. The arch is 10 m high and 5 m wide at the base. How wide is it 2 m from the vertex of the parabola?

Answer:

The origin of the coordinate plane is taken at the vertex of the arch in such a way that its vertical axis is along the negative y-axis.

This can be diagrammatically represented as

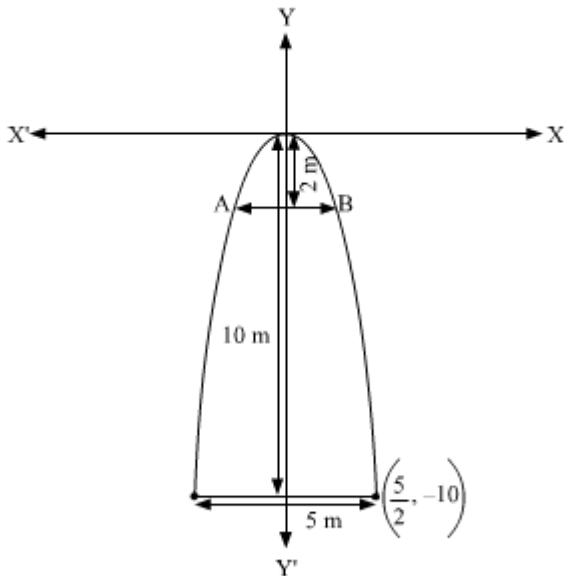

The equation of the parabola is of the form $x^2 = -4ay$ (as it is opening downwards).

It can be clearly seen that the parabola passes through point $(\frac{5}{2}, -10)$.

$(\frac{5}{2})^2 = -4a(-10) \Rightarrow 4a = \frac{25}{4} \times 10 = 62.5$ Therefore, the arch is in the form of a parabola whose equation is

$$x^2 = -62.5y.$$

When $y = -2$,

$x^2 = -62.5(-2) \Rightarrow x^2 = 125 \Rightarrow x = \sqrt{125} \approx 11.18$

$$\therefore AB = 2 \times 11.18 \text{ m} = 22.36 \text{ m} \approx 22.36 \text{ m}$$

Hence, when the arch is 2 m from the vertex of the parabola, its width is approximately 22.36 m.

Question 3:

The cable of a uniformly loaded suspension bridge hangs in the form of a parabola. The roadway which is horizontal and 100 m long is supported by vertical wires attached to the

cable, the longest wire being 30 m and the shortest being 6 m. Find the length of a supporting wire attached to the roadway 18 m from the middle.

Answer:

The vertex is at the lowest point of the cable. The origin of the coordinate plane is taken as the vertex of the parabola, while its vertical axis is taken along the positive y-axis. This can be diagrammatically represented as

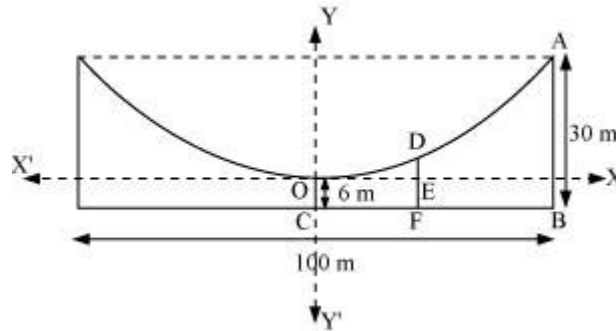

Here, AB and OC are the longest and the shortest wires, respectively, attached to the cable.

DF is the supporting wire attached to the roadway, 18 m from the middle.

Here, $AB = 30$ m, $OC = 6$ m, and $BC = \frac{100}{2} = 50$ m.

The equation of the parabola is of the form $x^2 = 4ay$ (as it is opening upwards).

The coordinates of point A are $(50, 30 - 6) = (50, 24)$.

Since A $(50, 24)$ is a point on the parabola,

$$(50)^2 = 4a(24)$$

$$\Rightarrow a = \frac{50 \times 50}{4 \times 24} = \frac{625}{24}$$

\therefore Equation of the parabola, $x^2 = 4 \times \frac{625}{24} \times y$ or $6x^2 = 625y$

The x-coordinate of point D is 18.

Hence, at $x = 18$,

$$6(18)^2 = 625y$$

$$\Rightarrow y = \frac{6 \times 18 \times 18}{625}$$

$$\Rightarrow y = 3.11 \text{ (approx)}$$

$\therefore DE = 3.11$ m

$DF = DE + EF = 3.11 \text{ m} + 6 \text{ m} = 9.11 \text{ m}$

Thus, the length of the supporting wire attached to the roadway 18 m from the middle is approximately 9.11 m.

Question 4:

An arch is in the form of a semi-ellipse. It is 8 m wide and 2 m high at the centre. Find the height of the arch at a point 1.5 m from one end.

Answer:

Since the height and width of the arc from the centre is 2 m and 8 m respectively, it is clear that the length of the major axis is 8 m, while the length of the semi-minor axis is 2 m.

The origin of the coordinate plane is taken as the centre of the ellipse, while the major axis is taken along the x-axis. Hence, the semi-ellipse can be diagrammatically represented as

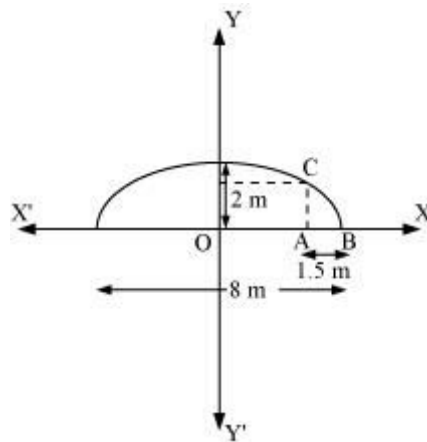

The equation of the semi-ellipse will be of the form $\frac{x^2}{a^2} + \frac{y^2}{b^2} = 1, y \geq 0$, where a is the semi-major axis

Accordingly, $2a = 8 \Rightarrow a = 4$

$b = 2$

Therefore, the equation of the semi-ellipse is $\frac{x^2}{16} + \frac{y^2}{4} = 1, y \geq 0$... (1)

Let A be a point on the major axis such that $AB = 1.5$ m.

Draw $AC \perp OB$.

$OA = (4 - 1.5) \text{ m} = 2.5 \text{ m}$

The x-coordinate of point C is 2.5.

On substituting the value of x with 2.5 in equation (1), we obtain

$$\begin{aligned} \frac{(2.5)^2}{16} + \frac{y^2}{4} &= 1 \\ \Rightarrow \frac{6.25}{16} + \frac{y^2}{4} &= 1 \\ \Rightarrow y^2 &= 4 \left(1 - \frac{6.25}{16} \right) \\ \Rightarrow y^2 &= 4 \left(\frac{9.75}{16} \right) \\ \Rightarrow y^2 &= 2.4375 \\ \Rightarrow y &= 1.56 \quad (\text{approx.}) \end{aligned}$$

$\therefore AC = 1.56 \text{ m}$

Thus, the height of the arch at a point 1.5 m from one end is approximately 1.56 m.

Question 5:

A rod of length 12 cm moves with its ends always touching the coordinate axes. Determine the equation of the locus of a point P on the rod, which is 3 cm from the end in contact with the x-axis.

Answer:

Let AB be the rod making an angle θ with OX and P (x, y) be the point on it such that AP = 3 cm.

Then, PB = AB – AP = (12 – 3) cm = 9 cm [AB = 12 cm]

From P, draw $PQ \perp OY$ and $PR \perp OX$.

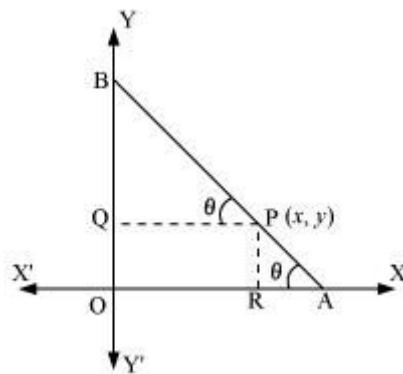

$$\text{In } \triangle PBQ, \quad \cos \theta = \frac{PQ}{PB} = \frac{x}{9}$$

$$\text{In } \triangle PRA, \quad \sin \theta = \frac{PR}{PA} = \frac{y}{3}$$

Since, $\sin^2 \theta + \cos^2 \theta = 1$,

$$\left(\frac{y}{3}\right)^2 + \left(\frac{x}{9}\right)^2 = 1$$

$$\text{Or, } \frac{x^2}{81} + \frac{y^2}{9} = 1$$

Thus, the equation of the locus of point P on the rod is $\frac{x^2}{81} + \frac{y^2}{9} = 1$.

Question 6:

Find the area of the triangle formed by the lines joining the vertex of the parabola $x^2 = 12y$ to the ends of its latus rectum.

Answer:

The given parabola is $x^2 = 12y$.

On comparing this equation with $x^2 = 4ay$, we obtain $4a = 12 \Rightarrow a = 3$

\therefore The coordinates of foci are $S(0, a) = S(0, 3)$

Let AB be the latus rectum of the given parabola.

The given parabola can be roughly drawn as

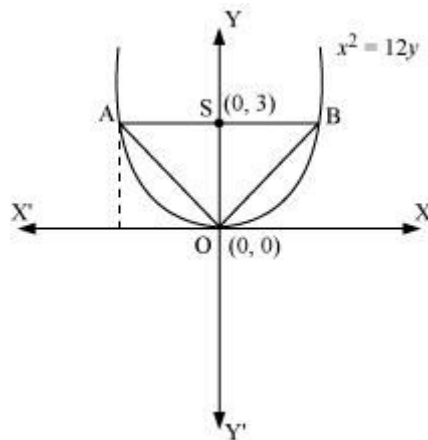

At $y = 3$, $x^2 = 12(3) \Rightarrow x^2 = 36 \Rightarrow x = \pm 6$

\therefore The coordinates of A are $(-6, 3)$, while the coordinates of B are $(6, 3)$.

Therefore, the vertices of ΔOAB are $O(0, 0)$, $A(-6, 3)$, and $B(6, 3)$.

$$\begin{aligned}
 \text{Area of } \triangle OAB &= \frac{1}{2} |0(3-3) + (-6)(3-0) + 6(0-3)| \text{ unit}^2 \\
 &= \frac{1}{2} |(-6)(3) + 6(-3)| \text{ unit}^2 \\
 &= \frac{1}{2} |-18 - 18| \text{ unit}^2 \\
 &= \frac{1}{2} |-36| \text{ unit}^2 \\
 &= \frac{1}{2} \times 36 \text{ unit}^2 \\
 &= 18 \text{ unit}^2
 \end{aligned}$$

Thus, the required area of the triangle is 18 unit^2 .

Question 7:

A man running a racecourse notes that the sum of the distances from the two flag posts from him is always 10 m and the distance between the flag posts is 8 m. find the equation of the posts traced by the man.

Answer:

Let A and B be the positions of the two flag posts and $P(x, y)$ be the position of the man. Accordingly, $PA + PB = 10$.

We know that if a point moves in a plane in such a way that the sum of its distances from two fixed points is constant, then the path is an ellipse and this constant value is equal to the length of the major axis of the ellipse.

Therefore, the path described by the man is an ellipse where the length of the major axis is 10 m, while points A and B are the foci.

Taking the origin of the coordinate plane as the centre of the ellipse, while taking the major axis along the x-axis, the ellipse can be diagrammatically represented as

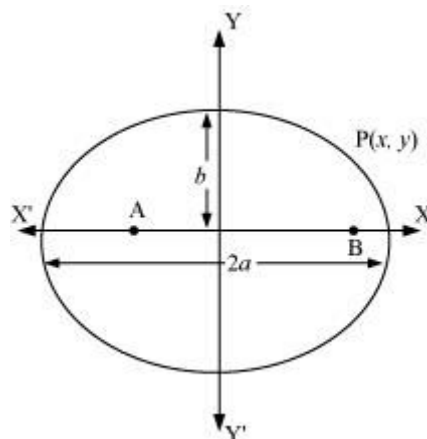

The equation of the ellipse will be of the form $\frac{x^2}{a^2} + \frac{y^2}{b^2} = 1$, where a is the semi-major axis

Accordingly, $2a = 10 \Rightarrow a = 5$

Distance between the foci ($2c$) = 8

$\Rightarrow c = 4$

On using the relation $c = \sqrt{a^2 - b^2}$, we obtain

$$4 = \sqrt{25 - b^2}$$

$$\Rightarrow 16 = 25 - b^2$$

$$\Rightarrow b^2 = 25 - 16 = 9$$

$$\Rightarrow b = 3$$

Thus, the equation of the path traced by the man is $\frac{x^2}{25} + \frac{y^2}{9} = 1$.

Question 8:

An equilateral triangle is inscribed in the parabola $y^2 = 4ax$, where one vertex is at the vertex of the parabola. Find the length of the side of the triangle.

Answer:

Let OAB be the equilateral triangle inscribed in parabola $y^2 = 4ax$.

Let AB intersect the x-axis at point C.

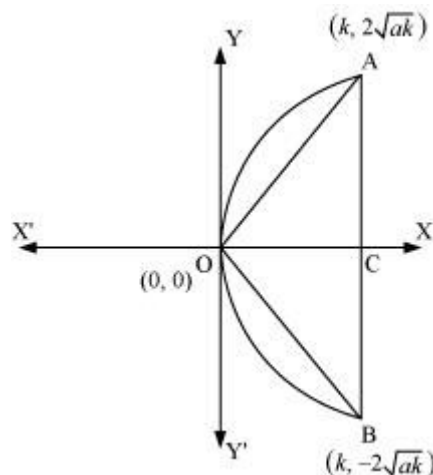

Let $OC = k$

From the equation of the given parabola, we have $y^2 = 4ak \Rightarrow y = \pm 2\sqrt{ak}$

\therefore The respective coordinates of points A and B are $(k, 2\sqrt{ak})$, and $(k, -2\sqrt{ak})$

$$AB = CA + CB = 2\sqrt{ak} + 2\sqrt{ak} = 4\sqrt{ak}$$

Since OAB is an equilateral triangle, $OA^2 = AB^2$.

$$\therefore k^2 + (2\sqrt{ak})^2 = (4\sqrt{ak})^2$$

$$\Rightarrow k^2 + 4ak = 16ak$$

$$\Rightarrow k^2 = 12ak$$

$$\Rightarrow k = 12a$$

$$\therefore AB = 4\sqrt{ak} = 4\sqrt{a \times 12a} = 4\sqrt{12a^2} = 8\sqrt{3}a$$

Thus, the side of the equilateral triangle inscribed in parabola $y^2 = 4ax$ is $8\sqrt{3}a$.
